

Environment Act Proposal Form



Name of the development: Western Concrete Products Brandon Ready Mix Concrete Batch Plant	
Type of development per Classes of Development Regulation (Manitoba Regulation 164/88): Class 1 Manufacturing	
Legal name of the proponent of the development: Gollstar Enterprises Ltd.	
Location (street address, city, town, municipality, legal description) of the development: 1620 and 1700 - 14th st. East Richmond Industrial Park Brandon, Manitoba R7A 7V2	
Name of proponent contact person for purposes of the environmental assessment: Rick Golletz	
Phone: 204-721-1250 Fax: 204-725-3762	Mailing address: 1920 Park Ave. Brandon, Manitoba R7B 0R9
Email address: rick@westernconcrete.mb.ca	
Webpage address:	
Date: March 18, 2013	Signature of proponent, or corporate principal of corporate proponent: Printed name: Rick Golletz

A complete **Environment Act Proposal (EAP)** consists of the following components:

- **Cover letter**
- **Environment Act Proposal Form**
- **Reports/plans supporting the EAP** (see "Information Bulletin - Environment Act Proposal Report Guidelines" for required information and number of copies)
- **Application fee** (Cheque, payable to Minister of Finance, for the appropriate fee)

Per Environment Act Fees Regulation (Manitoba Regulation 168/96):	
Class 1 Developments	\$500
Class 2 Developments	\$5,000
Class 3 Developments:	
Transportation and Transmission Lines.....	\$5,000
Water Developments	\$50,000
Energy and Mining.....	\$100,000

Submit the complete EAP to:

Director
Environmental Assessment and Licensing Branch
Manitoba Conservation
Suite 160, 123 Main Street
Winnipeg, Manitoba R3C 1A5

For more information:

Phone: (204) 945-7100
Fax: (204) 945-5229
Toll Free: 1-800-282-8069, ext. 7100
<http://www.gov.mb.ca/conservation/eal>



Planning & Building Safety Department
421 – 9th Street
Brandon, MB. R7A 4A9
204-729-2113

January 25, 2013

Our File: 44671-1-4

Rick Golletz
1920 Park Avenue
Brandon, MB
R7B 0R9

Dear Mr. Qumsieh:

Re: Zoning Confirmation for a concrete plant (Western Concrete) at 1620 & 1700 – 14th St. East
(Lot 3, Plan 44671 BLTO, and Lot 4, Block 1, Plan 44671 BLTO)

In response to your request for zoning confirmation of the above noted property, please be advised as follows:

1. The subject property is designated "Industrial" in the Brandon and Area Planning District Development Plan, By-law No. 78/01/04, as amended;
2. The subject property is classified "MG" Industrial General Zone, according to the City of Brandon Zoning By-law No. 6642, as amended; and
3. Limited manufacturing (concrete plant) is a permitted use in the "MG" Zone.

Further be advised that the above information is based solely on the existing zoning by-law and any amendments made to it. Use of land may be affected by other documents registered in the Brandon Land Titles Office, including documents registered by the City of Brandon that are not recorded in this office. It is therefore important to search all encumbrances registered against the land for complete information as to the permitted land use.

I trust this to be satisfactory.

Yours truly,

A handwritten signature in black ink, appearing to read "R. Eidick".

Ryan Eidick
Community Planner

DATE: 2013/03/27
TIME: 09:39

MANITOBA

STATUS OF TITLE

TITLE NO: 2138102/2

PAGE: 1

STATUS OF TITLE.....	ACCEPTED	PRODUCED FOR..	COUNTER
ORIGINATING OFFICE...	BRANDON	ADDRESS.....	
REGISTERING OFFICE...	BRANDON		
REGISTRATION DATE....	2006/01/27		
COMPLETION DATE.....	2006/01/30		
		CLIENT FILE...	NA
		PRODUCED BY...	G.GISLASON

LEGAL DESCRIPTION:

4431014 MANITOBA LTD.

IS REGISTERED OWNER SUBJECT TO SUCH ENTRIES RECORDED HEREON
IN THE FOLLOWING DESCRIBED LAND

LOT 3 BLOCK 1 PLAN 44671
EXC ONE-HALF INTEREST IN MINES AND MINERALS
OTHER THAN COAL AS SET FORTH IN TRANSFER NO. 93889

IN NE 1/4 12-10-19 WPM.

ACTIVE TITLE CHARGE(S):

90-3933/2	ACCEPTED	CAVEAT	REG'D: 1990/04/20
	FROM/BY:	CITY OF BRANDON	
	TO:		
	CONSIDERATION:	NOTES:	PT
1070893/2	ACCEPTED	CAVEAT	REG'D: 1999/10/22
	DESCRIPTION:	DEVELOPEMENT AGRT	
	FROM/BY:	THE CITY OF BRANDON	
	TO:	WILLIAM MAJCHER AS AGENT	
	CONSIDERATION:	NOTES:	PT
1144840/2	ACCEPTED	MORTGAGE	REG'D: 2004/05/03
	FROM/BY:	4431014 MANITOBA LTD.	
	TO:	WESTOBA CREDIT UNION LIMITED	
	CONSIDERATION:	\$3,000,000.00	NOTES: PT
1160666/2	ACCEPTED	CAVEAT	REG'D: 2005/04/07
	DESCRIPTION:	DEVELOPMENT AGREEMENT DATED 6 APRIL 2005	
	FROM/BY:	THE CITY OF BRANDON	
	TO:	TANYA MARSHALL AS AGENT	
	CONSIDERATION:	NOTES:	PT
1239460/2	ACCEPTED	CAVEAT	REG'D: 2009/03/23
	DESCRIPTION:	EASEMENT AGREEMENT DATED 21 NOVEMBER 2005	
	FROM/BY:	MB HYDRO, MTS ALLSTREAM, WESTMAN MEDICA CO-OPERATIVE	
	TO:	J. QUINN MENEK, BRENDA K MATTE, R BAZILEWICH AS AGENTS	
	CONSIDERATION:	NOTES:	PT RE PLAN 48481

CERTIFIED TRUE EXTRACT PRODUCED FROM THE LAND TITLES DATA
STORAGE SYSTEM ON 2013/03/27 OF TITLE NUMBER 2138102/2

DATE: 2013/03/27
TIME: 09:39

MANITOBA

STATUS OF TITLE

TITLE NO: 2138102/2

PAGE: 2

STATUS OF TITLE.....	ACCEPTED	PRODUCED FOR..	COUNTER
ORIGINATING OFFICE...	BRANDON	ADDRESS.....	
REGISTERING OFFICE...	BRANDON		
REGISTRATION DATE....	2006/01/27		
COMPLETION DATE.....	2006/01/30		
		CLIENT FILE...	NA
		PRODUCED BY...	G.GISLASON

ACTIVE TITLE CHARGE(S):

1239461/2	ACCEPTED	CAVEAT	REG'D: 2009/03/23
	DESCRIPTION:	GRANT OF RIGHT OF USER AGRT DATED 21 NOVEMBER 2005	
	FROM/BY:	CENTRA GAS MANITOBA INC.	
	TO:	J. QUINN MENEK AS AGENT	
	CONSIDERATION:		NOTES: PT RE PLAN 48481

ADDRESS(ES) FOR SERVICE:

EFFECT	NAME AND ADDRESS	POSTAL CODE
ACTIVE	4431014 MANITOBA LTD. 2404 PARK AVENUE BRANDON MB	R7A 0S3

ORIGINATING INSTRUMENT(S):

REGISTRATION NUMBER	TYPE	REG. DATE	CONSIDERATION	SWORN VALUE
1176184/2	TREQ	2006/01/27	\$0.00	\$0.00
	PRESENTED BY:	ROY, JOHNSTON & CO (BRANDON)		
	FROM:	4431014 MANITOBA LTD.		
	TO:			

FROM TITLE NUMBER(S):

1939340/2	PART	1979424/2	PART
-----------	------	-----------	------

LAND INDEX:

LOT	BLOCK	SURVEY PLAN
-----	-------	-------------

3	1	44671
NOTE:		EXC 1/2 INT M&M OTHER THAN COAL

ACCEPTED THIS 27TH DAY OF JANUARY, 2006
BY K.GRAINGER FOR THE DISTRICT REGISTRAR OF
THE LAND TITLES DISTRICT OF BRANDON.

CERTIFIED TRUE EXTRACT PRODUCED FROM THE LAND TITLES DATA
STORAGE SYSTEM ON 2013/03/27 OF TITLE NUMBER 2138102/2.

DATE: 2013/03/27
TIME: 09:38

MANITOBA
STATUS OF TITLE

TITLE NO: 2138103/2

PAGE: 1

STATUS OF TITLE..... ACCEPTED
ORIGINATING OFFICE... BRANDON
REGISTERING OFFICE... BRANDON
REGISTRATION DATE.... 2006/01/27
COMPLETION DATE..... 2006/01/30
PRODUCED FOR.. COUNTER
ADDRESS.....
CLIENT FILE... NA
PRODUCED BY... G.GISLASON

LEGAL DESCRIPTION:

4431014 MANITOBA LTD.

IS REGISTERED OWNER SUBJECT TO SUCH ENTRIES RECORDED HEREON
IN THE FOLLOWING DESCRIBED LAND

LOT 4 BLOCK 1 PLAN 44671
EXC ONE-HALF INTEREST IN MINES AND MINERALS
OTHER THAN COAL AS SET FORTH IN TRANSFER NO. 93889
IN NE 1/4 12-10-19 WPM.

ACTIVE TITLE CHARGE(S):

90-3933/2	ACCEPTED FROM/BY: TO: CONSIDERATION:	CAVEAT CITY OF BRANDON	REG'D: 1990/04/20
			NOTES: PT
1070893/2	ACCEPTED DESCRIPTION: FROM/BY: TO: CONSIDERATION:	CAVEAT DEVELOPEMENT AGRT THE CITY OF BRANDON WILLIAM MAJCHER AS AGENT	REG'D: 1999/10/22
			NOTES: PT
1144840/2	ACCEPTED FROM/BY: TO: CONSIDERATION:	MORTGAGE 4431014 MANITOBA LTD. WESTOBA CREDIT UNION LIMITED \$3,000,000.00	REG'D: 2004/05/03
			NOTES: PT
1160666/2	ACCEPTED DESCRIPTION: FROM/BY: TO: CONSIDERATION:	CAVEAT DEVELOPMENT AGREEMENT DATED 6 APRIL 2005 THE CITY OF BRANDON TANYA MARSHALL AS AGENT	REG'D: 2005/04/07
			NOTES: PT
1239460/2	ACCEPTED DESCRIPTION: FROM/BY: TO: CONSIDERATION:	CAVEAT EASEMENT AGREEMENT DATED 21 NOVEMBER 2005 MB HYDRO, MTS ALLSTREAM, WESTMAN MEDICA CO-OPERATIVE J. QUINN MENEK, BRENDA K MATTE, R BAZILEWICH AS AGENTS	REG'D: 2009/03/23
			NOTES: PT RE PLAN 48481

CERTIFIED TRUE EXTRACT PRODUCED FROM THE LAND TITLES DATA
STORAGE SYSTEM ON 2013/03/27 OF TITLE NUMBER 2138103/2

DATE: 2013/03/27
TIME: 09:38

MANITOBA
STATUS OF TITLE

TITLE NO: 2138103/2

PAGE: 2

STATUS OF TITLE.....	ACCEPTED	PRODUCED FOR..	COUNTER
ORIGINATING OFFICE...	BRANDON	ADDRESS.....	
REGISTERING OFFICE...	BRANDON		
REGISTRATION DATE....	2006/01/27		
COMPLETION DATE.....	2006/01/30		
		CLIENT FILE...	NA
		PRODUCED BY...	G.GISLASON

ACTIVE TITLE CHARGE(S):

1239461/2	ACCEPTED	CAVEAT	REG'D: 2009/03/23
	DESCRIPTION:	GRANT OF RIGHT OF USER AGRT DATED 21 NOVEMBER 2005	
	FROM/BY:	CENTRA GAS MANITOBA INC.	
	TO:	J. QUINN MENEK AS AGENT	
	CONSIDERATION:		NOTES: PT RE PLAN 48481

ADDRESS(ES) FOR SERVICE:

EFFECT	NAME AND ADDRESS	POSTAL CODE
ACTIVE	4431014 MANITOBA LTD. 2404 PARK AVENUE BRANDON MB	R7A 0S3

ORIGINATING INSTRUMENT(S):

REGISTRATION NUMBER	TYPE	REG. DATE	CONSIDERATION	SWORN VALUE
1176184/2	TREQ	2006/01/27	\$0.00	\$0.00
	PRESENTED BY:	ROY, JOHNSTON & CO (BRANDON)		
	FROM:	4431014 MANITOBA LTD.		
	TO:			

FROM TITLE NUMBER(S):

1939340/2	PART	1979424/2	PART
-----------	------	-----------	------

LAND INDEX:

LOT	BLOCK	SURVEY PLAN
4	1	44671

NOTE: EXC 1/2 INT M&M OTHER THAN COAL

ACCEPTED THIS 27TH DAY OF JANUARY, 2006
BY K.GRAINGER FOR THE DISTRICT REGISTRAR OF
THE LAND TITLES DISTRICT OF BRANDON.

CERTIFIED TRUE EXTRACT PRODUCED FROM THE LAND TITLES DATA
STORAGE SYSTEM ON 2013/03/27 OF TITLE NUMBER 2138103/2.

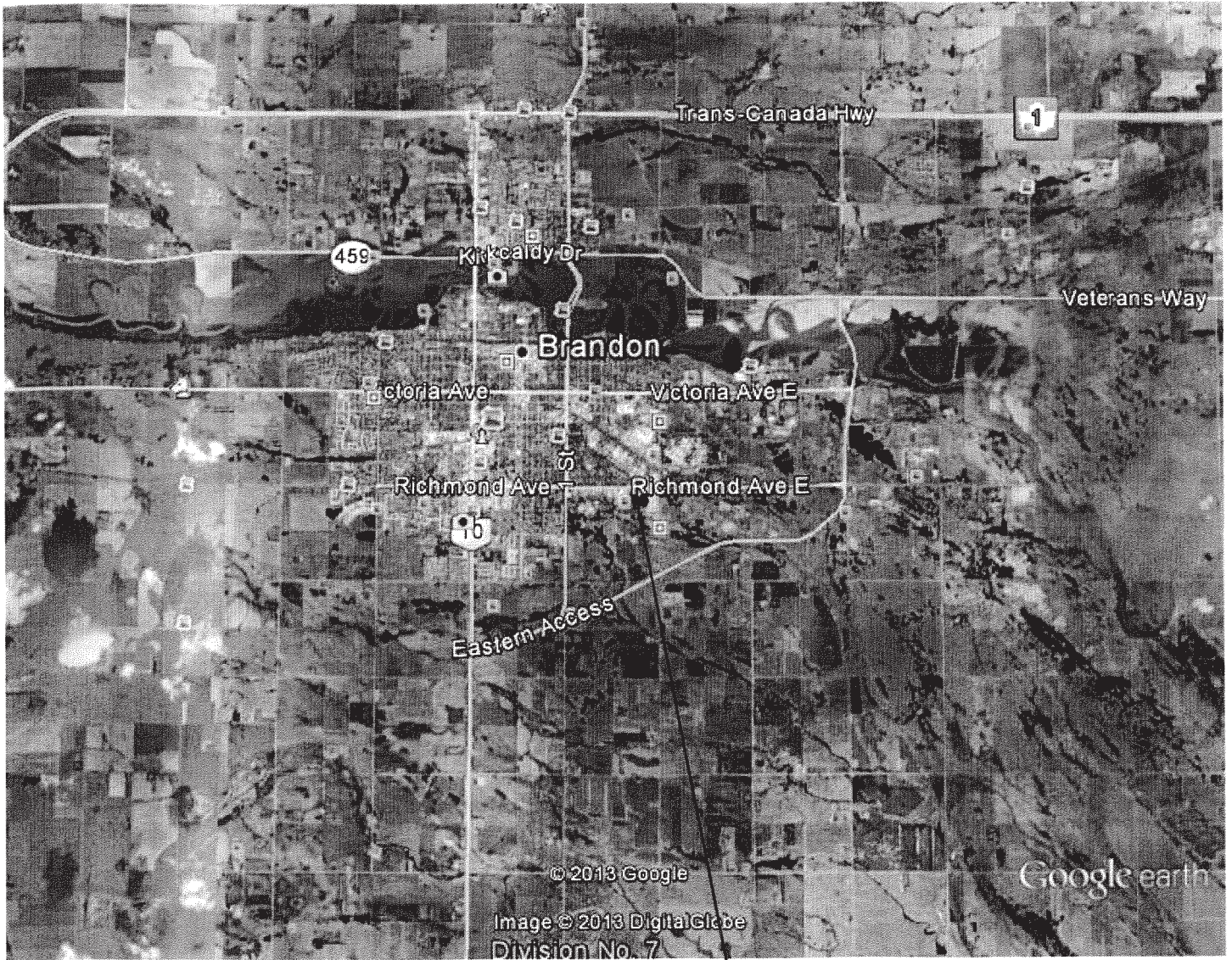

Google earth



RICHMOND INDUSTRIAL PARK

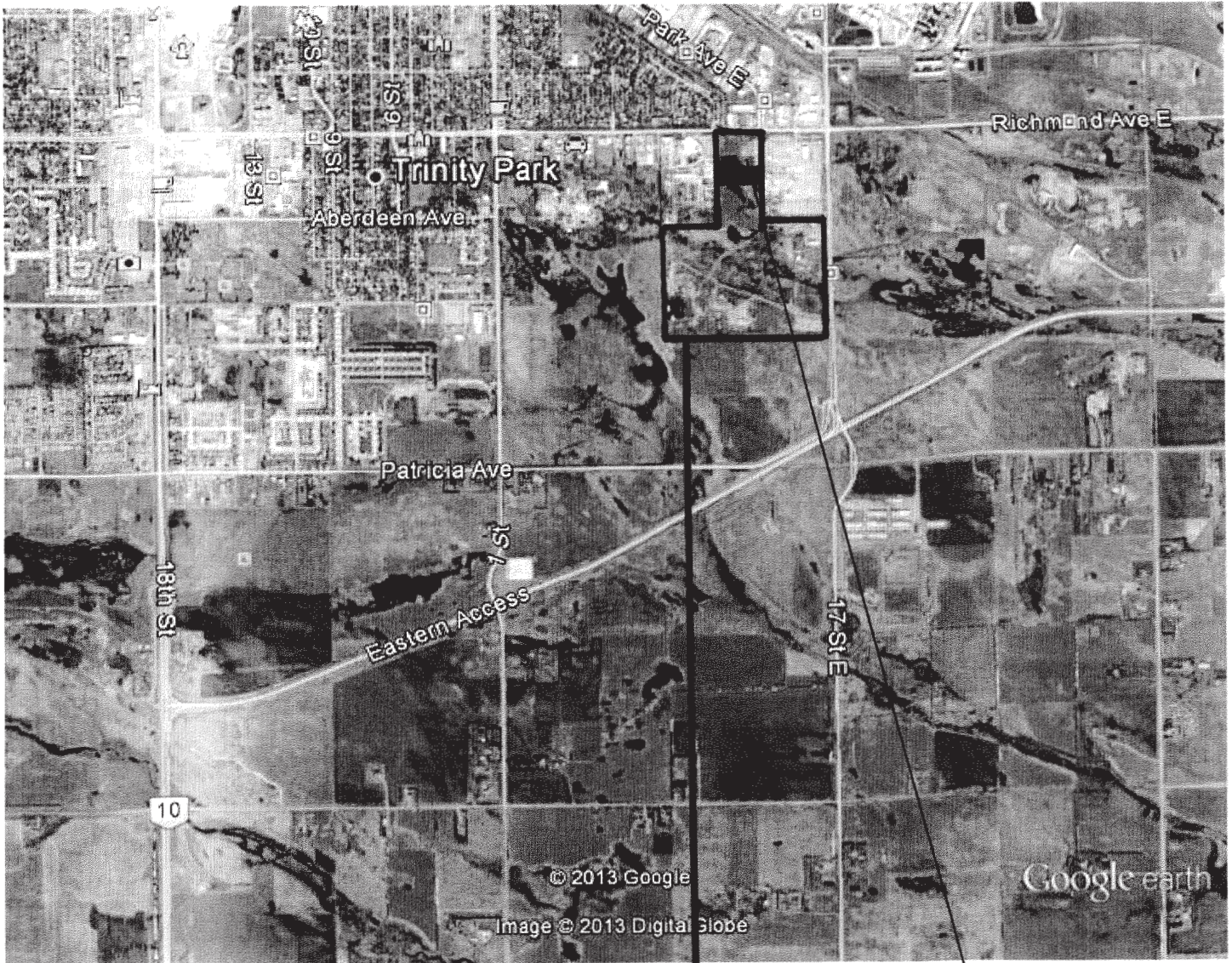

Google earth



LOT SITE

RICHMOND
INDUSTRIAL
PARK

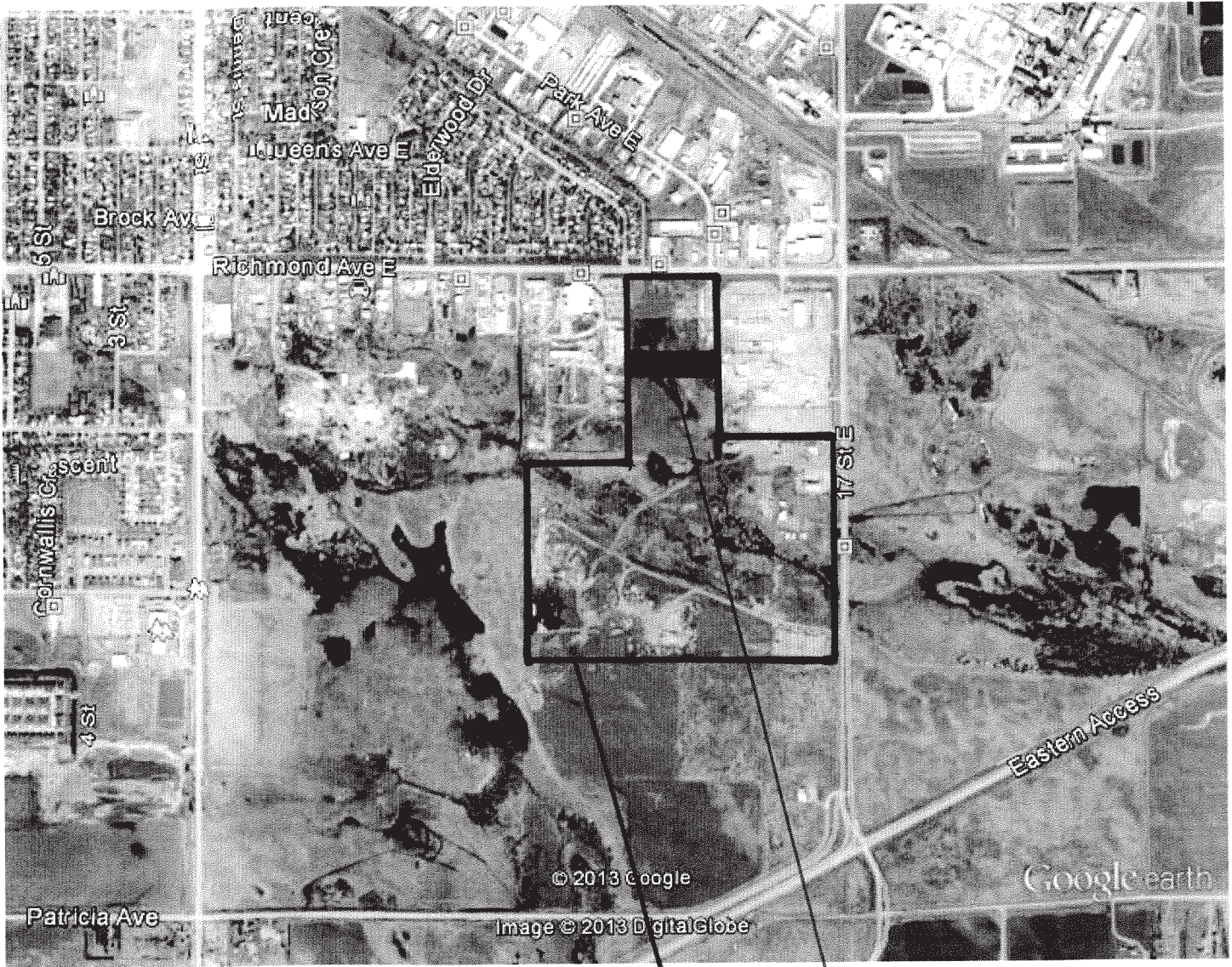

Google earth



LOT SITE

RICHMOND INDUSTRIAL SITE

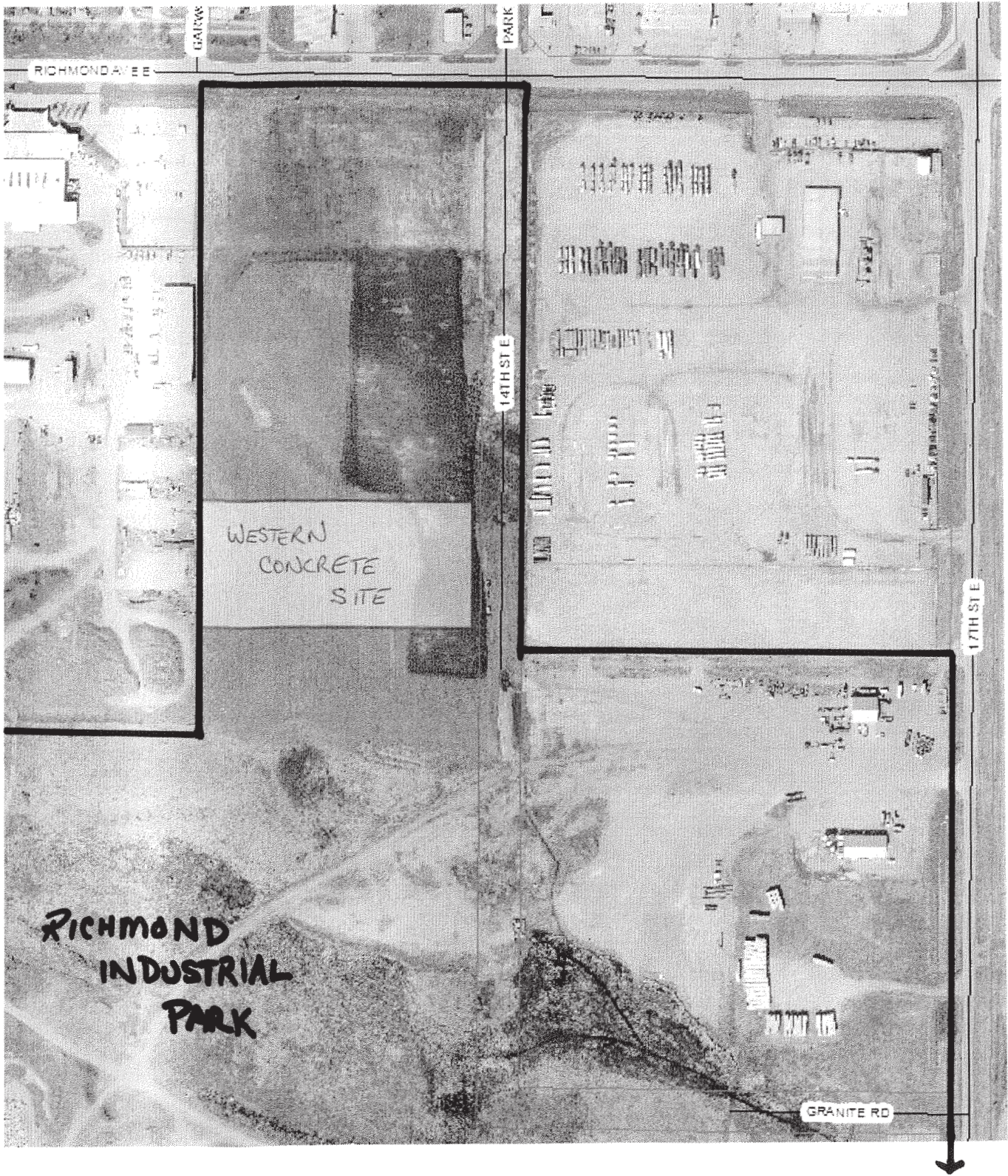

**RICHMOND
INDUSTRIAL
PARK**

WESTERN
CONCRETE
SITE

RICHMOND AVE

GARW

PARK

14TH STE

17TH STE

GRANITE RD



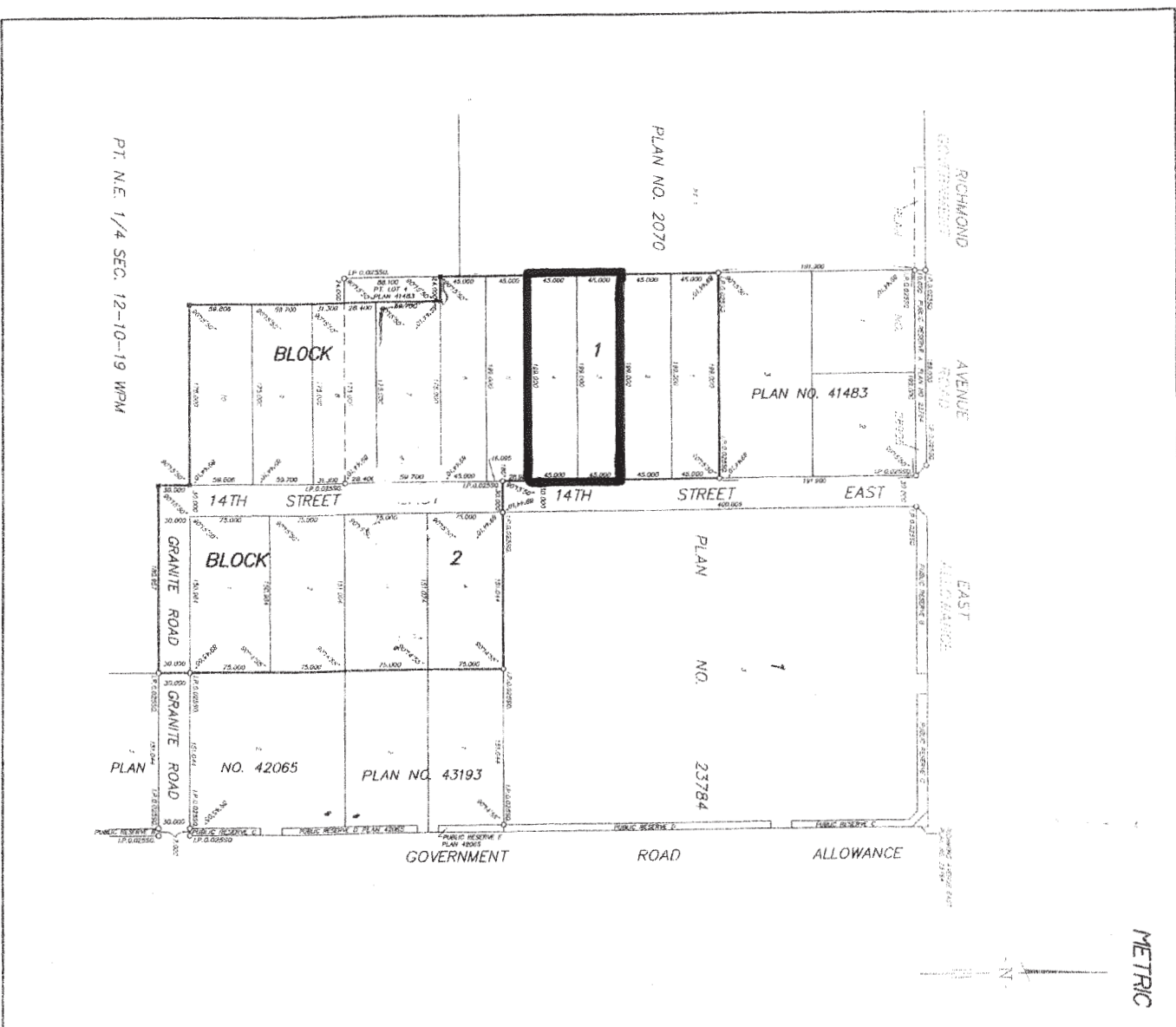

PT. N.E. 1/4 SEC. 12-10-19 WPM

METRIC



<p>ORIGINAL</p> <p>PLAN OF SUBDIVISION</p> <p>OF PART OF</p> <p>NE 1/4 SEC. 12, TWP. 10, RGE. 19 WPM,</p> <p>INCLUDING PART OF LOT 4 PLAN NO. 41483</p> <p>EXCEPTING THEREOUT LINES AND INTERALS NOT INCLUDED IN THE TITLE TO THE SURFACE</p> <p>BRANDON</p> <p>MANTOBA</p> <p>SCALE: 1:2000</p> <p>10m 20m 30m</p>		<p>Deposit No. 435/2005</p>
<p>NOTES</p> <p>All distances given in meters and may be converted to feet by multiplying by 3.28084.</p> <p>All bearings are given in degrees, minutes and seconds from the meridian and shall be read from the point of beginning to the next point in the order in which they are given.</p> <p>All areas referred to are on record in the Brown Land Titles Office.</p> <p>Lot 4 created by the registration of the plan is shown shaded blue.</p>		
<p>APPEAL</p> <p>I, Brandon Manton, being of the City of Brandon, Manitoba, Land Surveyor, make oath and say that I do hereby depose and swear that the above is a true and correct copy of the original plan as shown to me by the applicant and that the same is a true and correct copy of the original plan as shown to me by the applicant and that the same is a true and correct copy of the original plan as shown to me by the applicant.</p> <p>Brandon Manton Land Surveyor</p>		<p>Owner: Spaulding</p>
<p>APPROVALS</p> <p>Approved by Planning Committee of Brandon on 20th day of September, 2005.</p> <p>Approved by City Engineer on 20th day of September, 2005.</p> <p>Approved by City Council on 20th day of September, 2005.</p> <p>Approved by Planning Director Board on 20th day of September, 2005.</p> <p>Approved by City Engineer on 20th day of September, 2005.</p> <p>Approved by City Council on 20th day of September, 2005.</p>		<p>City of Brandon</p> <p>City Engineer</p>
<p>For Register Board</p> <p>Entered on register in the Brown Land Titles Office on 21st day of September, 2005.</p> <p>or PLAN NO. 44631</p>		<p>The approved is valid for 12 months unless registered.</p> <p>Approved on 21st day of September, 2005.</p> <p>City Engineer</p>
<p>By District Registrar</p> <p>Registration No. 1176183</p>		<p>Examined by Surveyor</p> <p>LENNY SQUIRES 211000</p> <p>1400 ROSSBY AVENUE, BRANDON, MANITOBA, S7N 1W1</p> <p>CEDS, F. NO. 4500-04-271</p>



PT. N.E. 1/4 SEC. 12-10-19 WPM

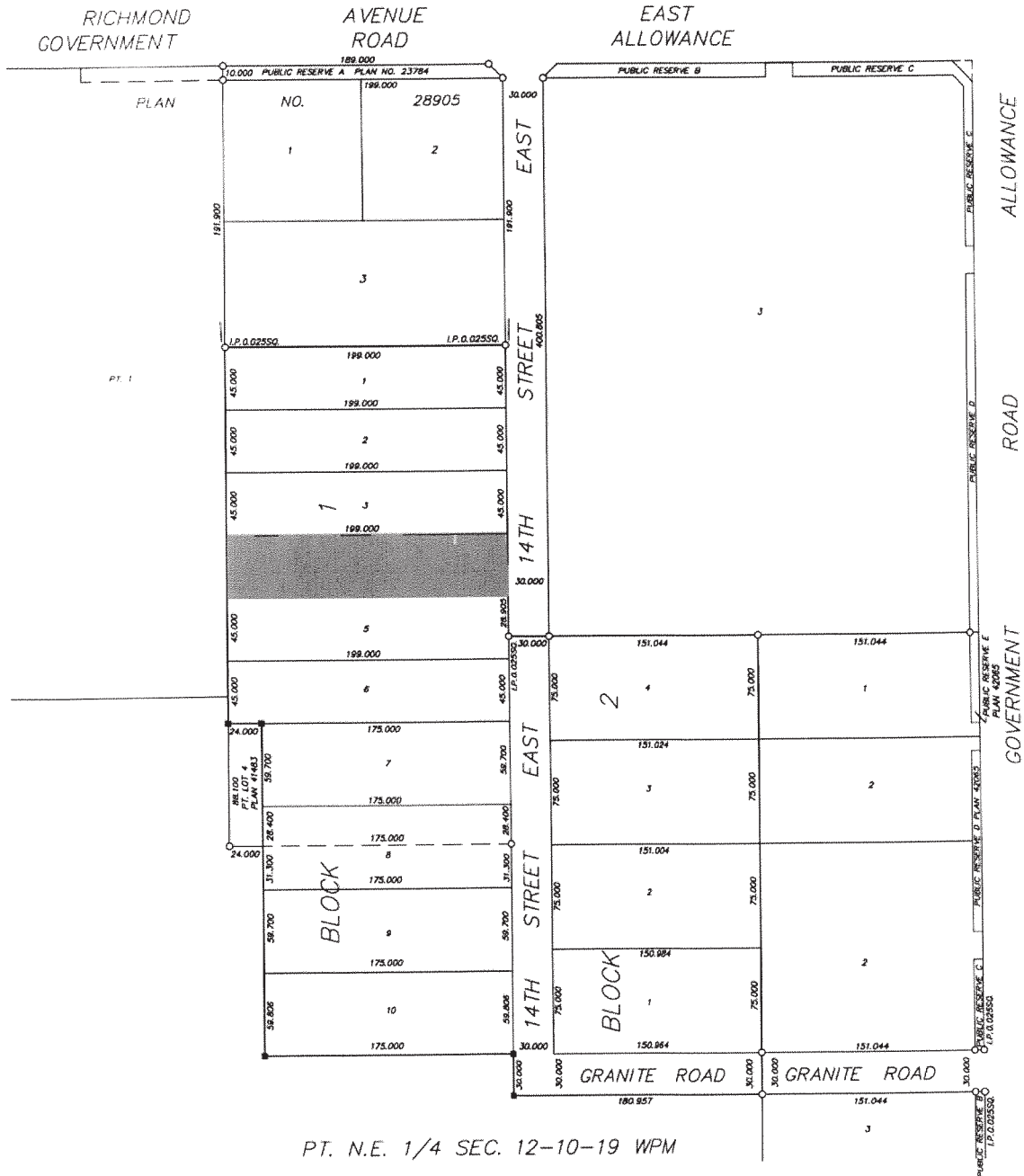



**WESTERN
CONCRETE**
PRODUCTS

1920 Park Avenue

Brandon, Manitoba R7B 0R9

Telephone (204) 728-2240

Fax (204) 725-3762

February 20, 2013

Environmental Assessment and Licensing Branch

Manitoba Conservation

Suite 160, 123 Main St.,

Winnipeg, Manitoba R3C 1A5

Attention: Director:

Re: ENVIRONMENT ACT PROPOSAL – READY MIX CONCRETE BATCH PLANT, BRANDON, MB.

Attached is our submittal for establishment of a permanent ready mix concrete production facility in the industrial park zone in Brandon, Manitoba.

Name of Development: Western Concrete Products Ltd.

– Brandon Concrete Batch Plant –

Type of Development: Class1 Manufacturing – Concrete Batch Plant

Legal Name of the Proponent of the Development: Gollstar Enterprises Ltd.

Location: 1620 and 1700 – 14th St. East

Richmond Industrial Park

Brandon, Manitoba R7A 7V2

Name of Proponent Contact Person: Rick Golletz

Phone: (204) 721-1250

Fax: (204) 725-3762

e-mail address: rick@westernconcrete.mb.ca

Mailing Address: 1920 Park Ave. Brandon, Manitoba R7B 0R9

The plant will be owned and operated all year round by Western Concrete Products of Brandon, Manitoba.

1). The plant will be located on the property depicted as Lot 3, Plan 44671 BLTO, and Lot 4, Block 1, Plan 44671 BLTO (see attached Industrial Park Development Map). An offer to purchase said lots by Gollstar ENT. Ltd. from Richmond Industrial Park is currently in effect and contingent upon this environmental license application.

2). the proposed site is currently vacant land. It is within the Richmond Industrial Park with adjoining properties "MG" Industrial General Zone according to the City of Brandon Zoning By-Law No. 6642. The subject property is designated "Industrial" in the Brandon and Area Planning District Development Plan, By-law No. 78/01/04 and Limited manufacturing (concrete plant) is a permitted use in the "MG" Zone.

3). The batch plant is new equipment purchased from Erie Strayer and will be certified by the Manitoba Ready Mix Concrete Association as meeting all requirements of the CSA A23.1-04 Standard.

4). the batch plant will be operated Monday to Saturday from 7:00 am to 8:00pm, producing ready mix concrete for use off-site. The concrete will be put into mixer trucks for delivery to various locations within 100kms of the plant.

5). Batch Plant Equipment Details:

5.1 Batch Plant Manufacturer: Erie Strayer Co. Model MPB-11T

Plant is connected directly to MB Hydro Grid

5.2 Silos: P12-UPC#-2500 Unitized cement bin, pattern C-111. Three compartments manufactured by Erie Strayer Co.

5.3 Dust Collection System: C& W – CP – 7500 dust collector; single compartment dust collecting enclosure with: 1694 sq. ft. of cartridges; reverse pulse jet cleaning mechanism; Drive thru vis-A-Load dust shroud with telescoping lift frame; dust recycling system with 10HP blower and 3" piping to return dust to flyash compartment.

6. Batch Plant Operations: The following is a list of materials used and the process followed:

6.1 Aggregates:

a) Aggregates consisting of single sand (5mm down) and two or three types of gravel and/or crushed stone (10mm to 200mm max) will be delivered to the yard by dump trailer trucks. The aggregates will be placed into stock piles separated by concrete bin walls. (See attached Site Plan) Approximately 2000 tonnes of each material will be on site at any one time.

b) A rubber tired front end loader will move the material as required from the stock piles, up a loading ramp to the feeding aggregate bins of the batch plant equipment.

6.2 Cementitious materials:

a) Portland cements (Type GU) and Class C1 flyash will be delivered to the site silos by bulk tanker trucks. Each truck is equipped with an air blower system which enables it to blow the cement or fly ash into the appropriate silo. All three silos are interconnected to a common bag house. As the Cementitious product is being blown in, the resulting pressurized air causes some of the material within the silo to become airborne. The bag house consists of a series of hanging bags which filter this air borne material before it can be released to the atmosphere. Once the air pressure is normalized, the captured material drops by gravity back into the silo. This bag house is inspected and cleaned on a monthly basis.

Additionally the plant is equipped with a C & W Dust Collector that lowers a rubber-boot attached to a shroud surrounding the truck charging hopper while the truck is being loaded. This equipment will collect all the cementitious dust at the truck loading site and eventually deposit the cementitious material back into the flyash silo.

We see no potential impacts on the environment with respect to air pollutants.

b) The cement silo is manufactured with three bins with a total air volume of 2500 cu. ft. The silos combined will have a capacity of 300 tonnes. 200 tonnes of capacity for Portland Cement with a 100 tonne capacity for flyash. We anticipate approximately 4000 tonnes of cementitious materials to be siloed in this manner annually.

c) MSDS sheets for Portland cement and fly ash are appended.

6.3 Admixtures and chemicals, use and storage:

a) All of the chemicals used and stored on site are those commonly used as admixtures in the batching of concrete in order to impart particular properties to the concrete mixture. The chemicals are delivered by tanker truck as a bulk liquid by W.R.Grace and Co. Storage of each is as a liquid in rigid plastic storage tanks provided by W.R.Grace. These storage tanks are themselves within a secondary containment basin with a concrete floor and a concrete curbing sufficient to provide 110% containment of the largest tank (or 25% of the total storage, whichever is greater) should a rupture occur.

b) MSDS sheets for each product are attached for the following chemicals:

WRDA 64 CR-2409: Water-reducer/retarder meeting ASTM C494 C494M.

The product is an aqueous solution of Ignosulfonate, amine, and compound carbohydrates.

DARACEL: An admixture formulated to achieve a faster set acceleration as well as increased early strength development of the concrete.

Daravair 1400: Air entraining agent meeting ASTM C949 C494M. The product is an aqueous solution of neutralized resin acids and rosin acids.

ADVA 140: High range water-reducer. The product is a carboxylated polyether.

6.4 Water supply and management:

a) Potable water for production and washing will be supplied from the municipal supply provided by the City of Brandon.

b) A ready mixed concrete plant site typically uses water for the following operations associated with concrete production and delivery:

1. Mix water for batching concrete loads
2. Washing the truck down at the plant after loading
3. Washing the truck drum out at the end of the day
4. Filling the truck mounted water tanks
5. Dust suppression in the plant yard in high traffic areas

c) Water will be required at the rate of approximately 4000 litres per day. Each truck is also provided with an outside tank of water which may be used on a project for re-tempering a load and/or for an initial wash-down of the truck and chutes prior to the truck leaving a project.

7) Batching Process:

- a) Prior to commencement of batching, a redi-mix truck is positioned under the loading chute.
- b) For each batch, the requisite batch ingredients (Cementitious, water, aggregates and admixtures) are weighed or metered in a given sequence controlled by the batch plant computer. Cementitious is directly gravity discharged in a controlled manner from the silos; sand and coarse aggregates are discharged from the weigh-bins along a conveyor. Water and admixtures are added to the truck load by volume metering. The Erie Strayer Batch plant is a computer controlled and rated as automatic, with no manual operation required once the batch mix design has been selected and entered.
- c) Dust emitting from the truck loading area is controlled via fine tuning of the batching sequence to deliver a smooth, controlled flow of raw materials into the mixer with a combination of water addition to control dust emissions. Above and beyond this sequencing our firm has purchased a telescoping loading chute system that will minimize air-borne pollutants. Our third system focusing on dust minimization is the installation of the Model CP 7500 Dust Collector. The Drive Thru Vis-a-load dust shroud with telescoping lift frame and 7,500 CFM blower with a 15 HP TEFC electric motor ensures dust minimization and collects airborne products and recycles them back into the mix.
- d) Once all materials are in the truck's mixing drum, the revolution speed of the drum is increased to mixing speed for approximately 5 minutes prior to being reduced to agitating speed for travel on roads to the project site.

8) Recycling water and return concrete:

- a) Where operational and quality control restraints allow, any excess returned concrete is cycled into subsequent loads. Situations where returned concrete cannot be incorporated in subsequent loads, the left-over concrete is cast into forms and permitted to harden for the production of interlocking concrete blocks for resale. Once the partial load in the drum has been utilized, the truck is driven to the wash-out area bin.
- b) A designated washout area is provided to accept all materials from truck washout procedures. An adjacent wash water reclaim area is provided to allow reclaimed wash water to be free of settled slurry and aggregate particles.

Site grading is designed to manage all water from concrete production (including truck wash off procedures) to drain into the washout/ reclaim areas.

c) As required, the settling pond containing the cementitious, sand and stone is cleaned out by a loader bucket. The dredged material is deposited in an area adjacent to the settling pond where water drains back to the pond. Once dry, the solid materials are reclaimed and stockpiled for sale as a fill material or base under sidewalks, floors and pavements.

d) All storm water that may come into contact with batching materials or operations is controlled via drainage to truck washout/wash water reclaim areas. All remaining storm water is infiltrated on site via granular landscaping material and the natural vegetation buffer around the plant site.

e) The site is graded granular and sloped in a manner such that uncontaminated storm waters do not enter these ponds but instead are directed to storm sewers and ditching provided. The Industrial Park collects all storm water in an approved designated holding pond to properly hold volumes and control outflow rates to natural off site drainage.

f) The road leading into the yard will be covered by concrete laneways; the rest of the yard will be covered by free –draining gravel atop of local clay base material. Control of excessive dust will be provided by application of water as required; in extreme cases, application of a dust-control solution may be required.

9) Other:

There is no storage of diesel fuel, gasoline etc. on site. All fuelling of vehicles and maintenance of vehicles is performed off site.

To ensure all environmental concerns and precautions have been addressed and met, we follow the environmental guidelines of the Canadian Ready Mixed Concrete Association's *Environmental Management Practices for Ready Mixed Concrete Operations in Canada* (copy attached and available from www.mrmca.com/environmental) as well as the Manitoba Heavy Construction Association's *Best Environmental and Safety Management Practice for Redi-Mix Concrete Facilities*.

We foresee no potential impacts on the environment including air pollutants, ground water runoff, noise, fisheries, wildlife, or any other concerns.

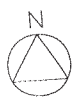
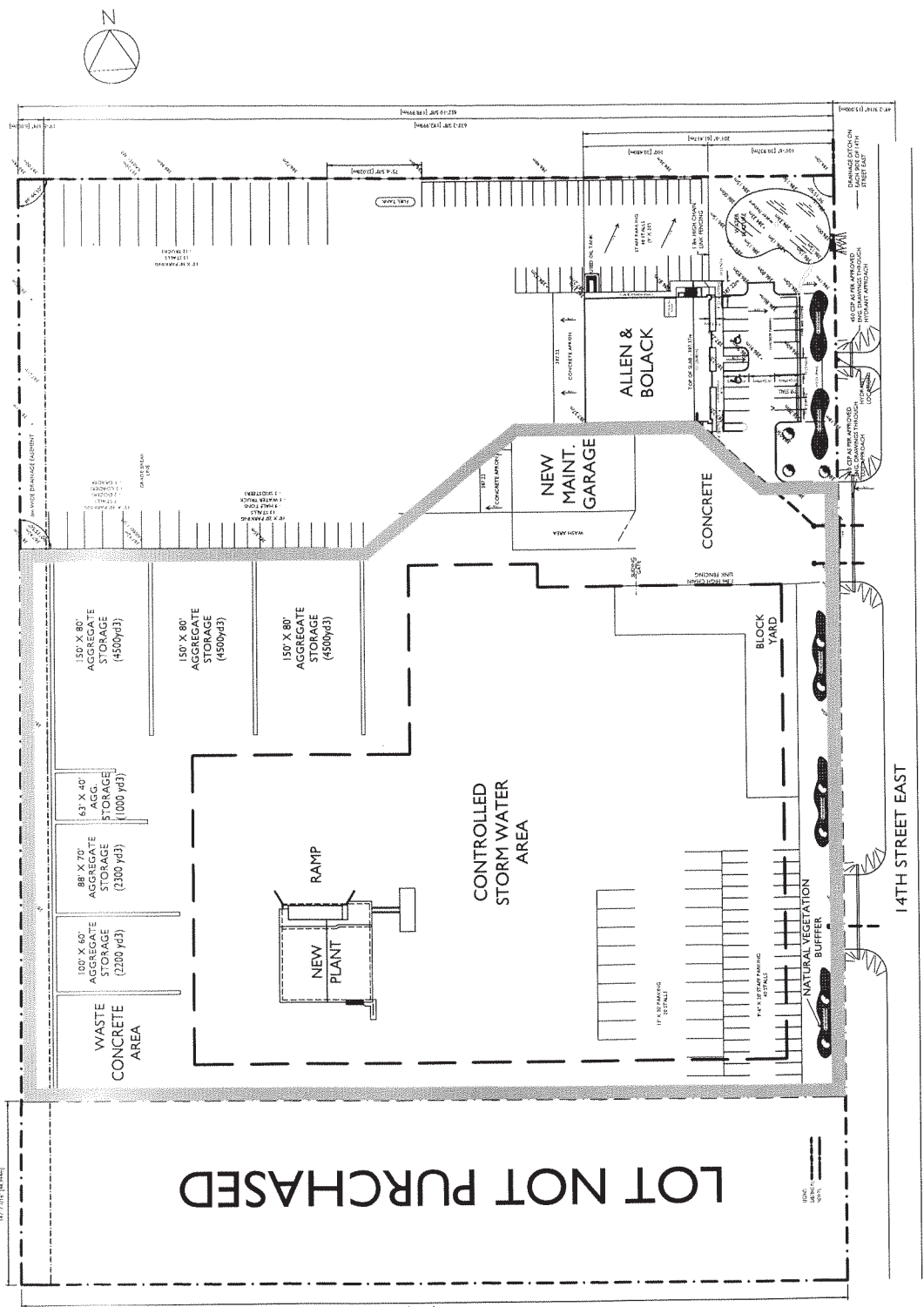

LOT NOT PURCHASED

PROJECT: BRANDON, MB
 DATE: FEBRUARY 1, 2013
 NEW BATCH PLANT
 SCALE: NOT TO SCALE
 SHEET: SITE PLAN

WESTERN CONCRETE PRODUCTS

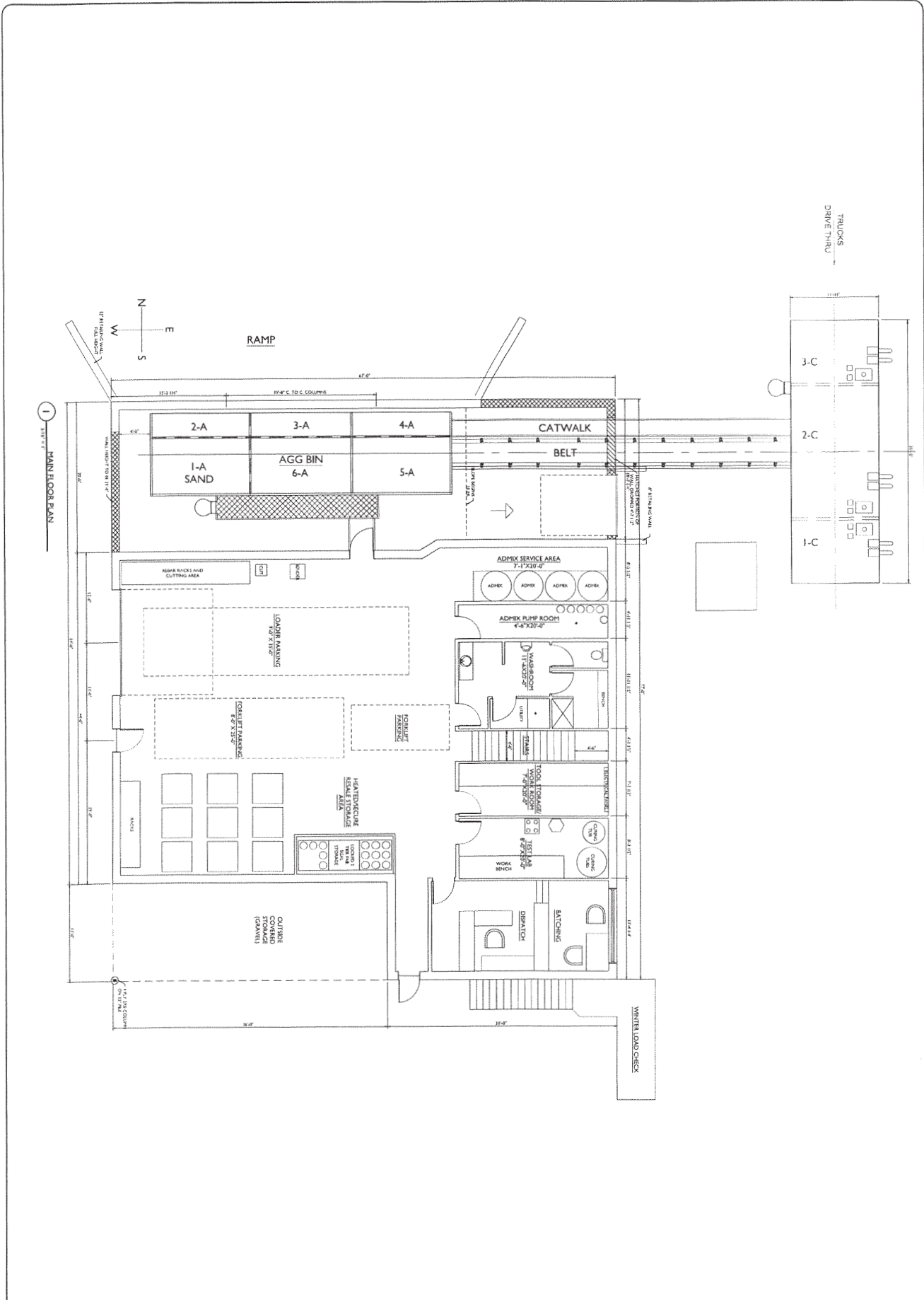

1 MAIN FLOOR PLAN

	DIRECTION NORTH	DRAWING NO. 13.81.23	PROJECT NAME WESTERN CONCRETE PLANT
	SHEET NUMBER A2	DATE 12/11/14	SHEET NAME MAIN FLOOR
DO NOT SCALE DRAWING CONTRACTOR SHALL VERIFY ALL DIMENSIONS AND LOCATIONS OF ALL STRUCTURE SHALL BE THE RESPONSIBILITY OF THE CONTRACTOR. CONTRACTOR SHALL VERIFY ALL DIMENSIONS AND LOCATIONS OF ALL STRUCTURE SHALL BE THE RESPONSIBILITY OF THE CONTRACTOR. CONTRACTOR SHALL VERIFY ALL DIMENSIONS AND LOCATIONS OF ALL STRUCTURE SHALL BE THE RESPONSIBILITY OF THE CONTRACTOR.		REVISIONS NO. DATE DESCRIPTION	ENGINEER STAMP ARCHITECT STAMP

D M E
 J & G
 Drandon, MD.
 1364 PARK AVE. BRANDON, MD. 20611
 P 301.778.3331 F 301.778.3334
 E jgand@jdgand.com

THIS DRAWING AND ITS CONTENTS ARE THE PROPERTY OF J & G CONCRETE, INC. AND SHALL NOT BE REPRODUCED WITHOUT WRITTEN CONSENT OF THE DESIGNER.

PROJECT NUMBER
DATE: 01/11/2011

THIS DRAWING IS THE PROPERTY OF J.S. COMPANY AND MAY NOT BE REPRODUCED WITHOUT WRITTEN CONSENT OF THE DESIGNER.
THE NUMBER 2011001
THIS DRAWING IS THE PROPERTY OF J.S. COMPANY AND MAY NOT BE REPRODUCED WITHOUT WRITTEN CONSENT OF THE DESIGNER.
THE NUMBER 2011001
THIS DRAWING IS THE PROPERTY OF J.S. COMPANY AND MAY NOT BE REPRODUCED WITHOUT WRITTEN CONSENT OF THE DESIGNER.
THE NUMBER 2011001

WESTERN CONCRETE PLANT
EXTERN ELEVATIONS
DATE: 01/11/2011
DRAWN BY: J.S.
CHECKED BY: J.S.
PROJECT NAME: WESTERN CONCRETE PLANT
SHEET NUMBER: 01

ARCHITECT: J.S. COMPANY
NOTES:
1. REFER TO SHEET 01 FOR GENERAL NOTES.
2. REFER TO SHEET 02 FOR FOUNDATION PLAN.
3. REFER TO SHEET 03 FOR FLOOR PLAN.
4. REFER TO SHEET 04 FOR ROOF PLAN.
5. REFER TO SHEET 05 FOR SECTION 1-1.
6. REFER TO SHEET 06 FOR SECTION 2-2.
7. REFER TO SHEET 07 FOR SECTION 3-3.
8. REFER TO SHEET 08 FOR SECTION 4-4.
9. REFER TO SHEET 09 FOR SECTION 5-5.
10. REFER TO SHEET 10 FOR SECTION 6-6.

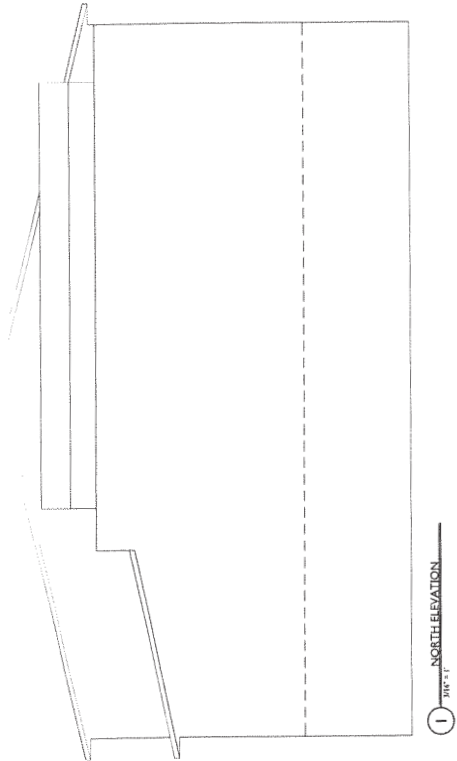
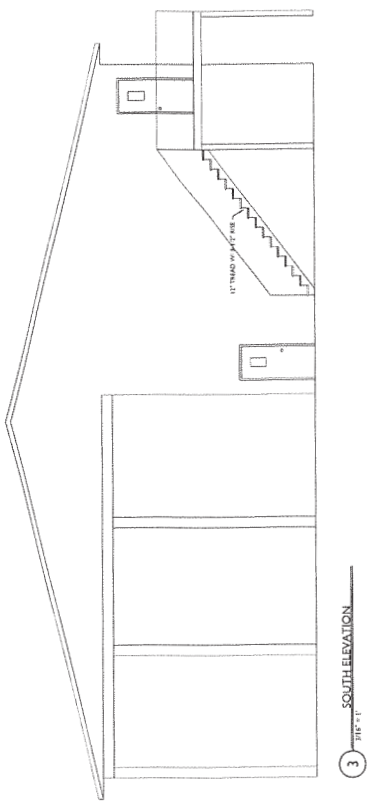
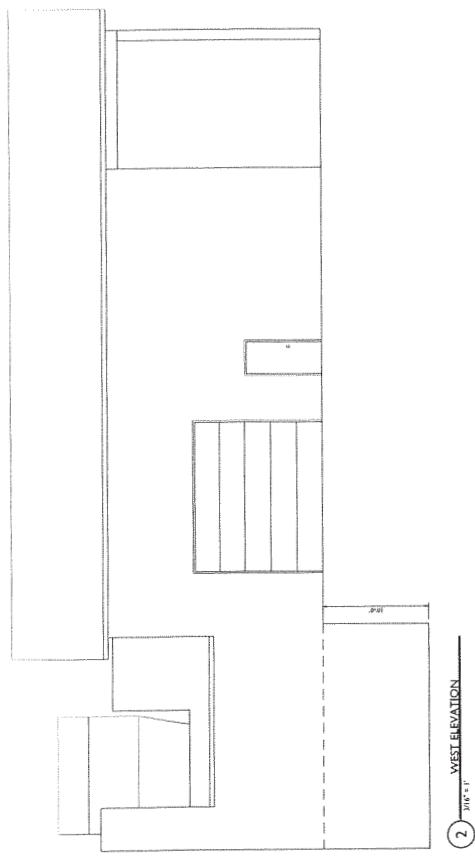
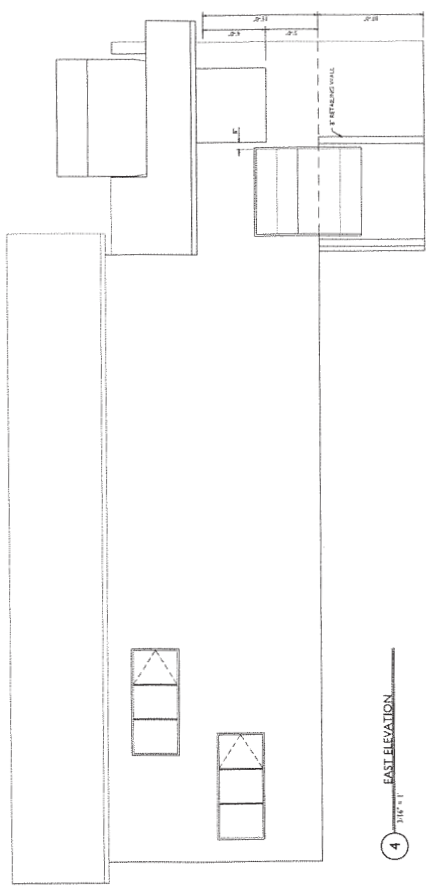

A3

SHEET NUMBER

THIS DRAWING IS THE PROPERTY OF J. S. GARDNER, INC. AND SHALL NOT BE REPRODUCED WITHOUT WRITTEN CONSENT OF THE DESIGNER.

PROJECT NAME	WESTERN CONCRETE PLANT
SHEET NAME	BUILDING SECTIONS & WALL
DATE	
DESIGNED BY	
CHECKED BY	
APPROVED BY	
DATE	
PROJECT NO.	
DRAWN BY	
DATE	
PROJECT NAME	WESTERN CONCRETE PLANT
SHEET NAME	BUILDING SECTIONS & WALL
DATE	
DESIGNED BY	
CHECKED BY	
APPROVED BY	
DATE	
PROJECT NO.	
DRAWN BY	
DATE	

J S GARDNER, INC.
1100 W. 10TH ST. SUITE 100
DENVER, CO 80202
TEL: 303.733.1100
WWW.JSGARDNER.COM

PROJECT NAME	WESTERN CONCRETE PLANT
SHEET NAME	BUILDING SECTIONS & WALL
DATE	
DESIGNED BY	
CHECKED BY	
APPROVED BY	
DATE	
PROJECT NO.	
DRAWN BY	
DATE	

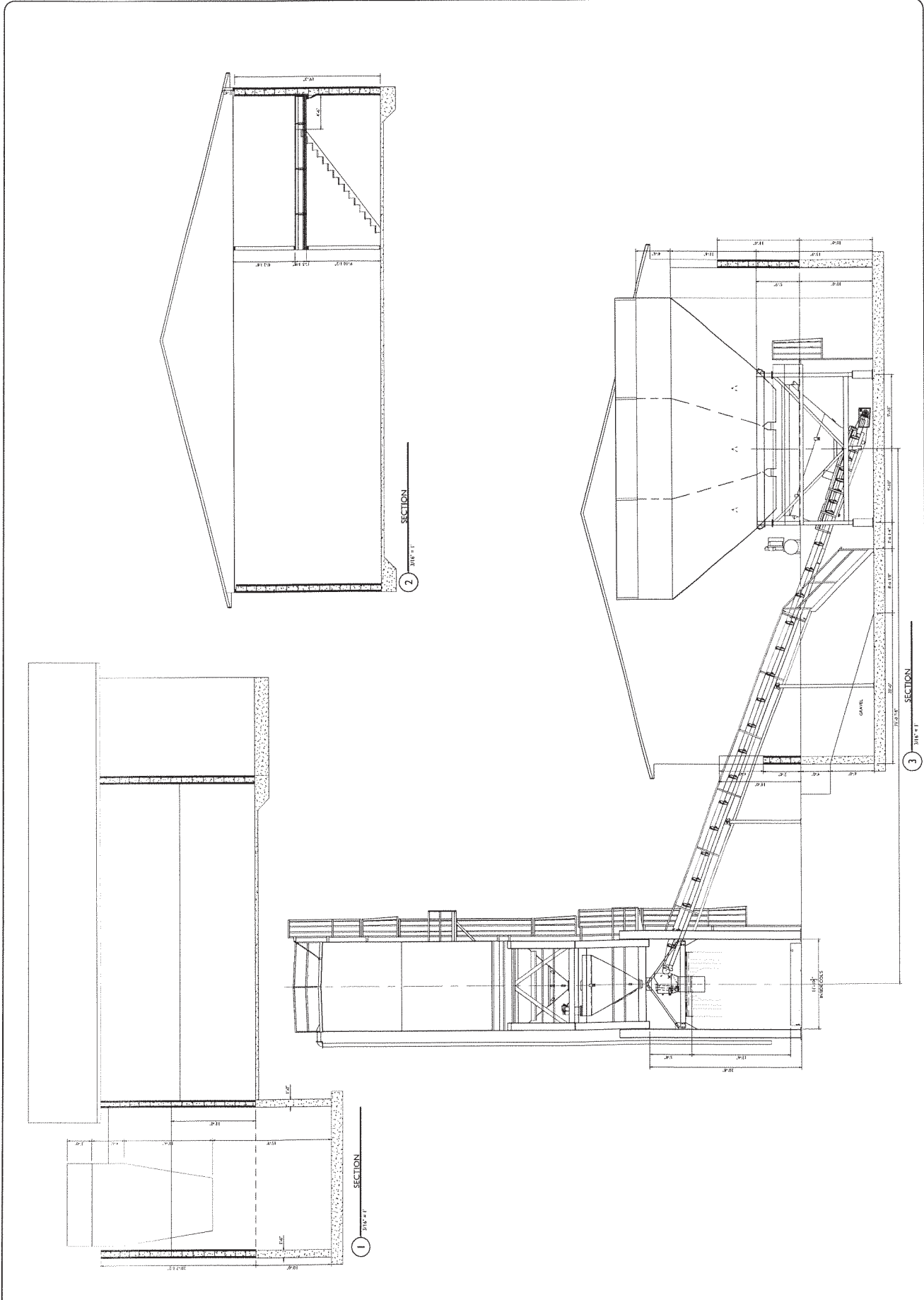

BY ERIE STRAYER CO.

MPB-11T

- 1 AGGREGATE BIN 6 COMPARTMENT PATT. A-222
255 CU YD HEAPED CAPACITY
- 2 REMOVABLE BIN EXTENSIONS
- 3 HEATING REGISTERS
- 4 PARTITION & END EXTENSIONS
- 5 SIDE SPILL PLATE
- 6 SUPPORT SILL - 4 REQ'D
- 7 15 CU YD AGG BATCHER W/TWO DISCHARGE GATES
- 8 36" INCLINED BATCH TRANSFER CONVEYOR
78" - 10 3/4" C. TO C. W/ 40 H.P. DRIVE & WALKWAY
ON ONE SIDE WITH ACCESS STAIRWAY
- 9 TRUCK CHARGING CHUTE W/ 1'-8" STEEL EXTENSION
- 10 15 CU YD CEMENT BATCHER
- 11 CEMENT BATCH PLATFORM W/ HANDRAILS
- 12 P12-JUPC3-2500 CEM BIN (PATT. C-111)
3 COMPARTMENTS FOR CEMENT
- 13 LOWER COLUMNS & BRACING
- 14 AIR LOADING PIPING 5" DIA. (6 REQ'D)
- 15 LADDER WITH SAFETY CAGE FROM GRADE
TO CEM BIN ROOF W/ ACCESS TO BATCH PLATFORM
- 16 CEMENT UNITIZED SECTION
- 17 3" WATER METER
- 18 MOTOR CONTROL PANEL
- 19 7 HP AERATION BLOWER
- 20 CEMENT BATCHER FILTER VENT
- 21 CEMENT ROOF HANDRAILS
- 22 DUST COLLECTION SYSTEM FOR CEMENT BIN
& TRUCK CHARGING CHUTE
- 23 30 H.P. AIR COMPRESSOR W/ 120 GAL. TANK
- 24 AGG BIN HOPPER GATE SERVICE PLATFORM
W/ ACCESS LADDER TO GRADE
- 25 CEMENT BIN VALVE SERVICE PLATFORM
W/ HANDRAILS
- 26 CONTROL SYSTEM
- 27 POLARMATIC 1.5 MW WATER HEATING SYSTEM

BY OTHERS

CEM BIN CAPACITIES
COMPTS 1-C & 3-C EACH
2500 CU. FT. AIR VOL
92 CU. YD.
COMPT 2-C
5000 CU. FT. AIR VOL
185 CU. YD.

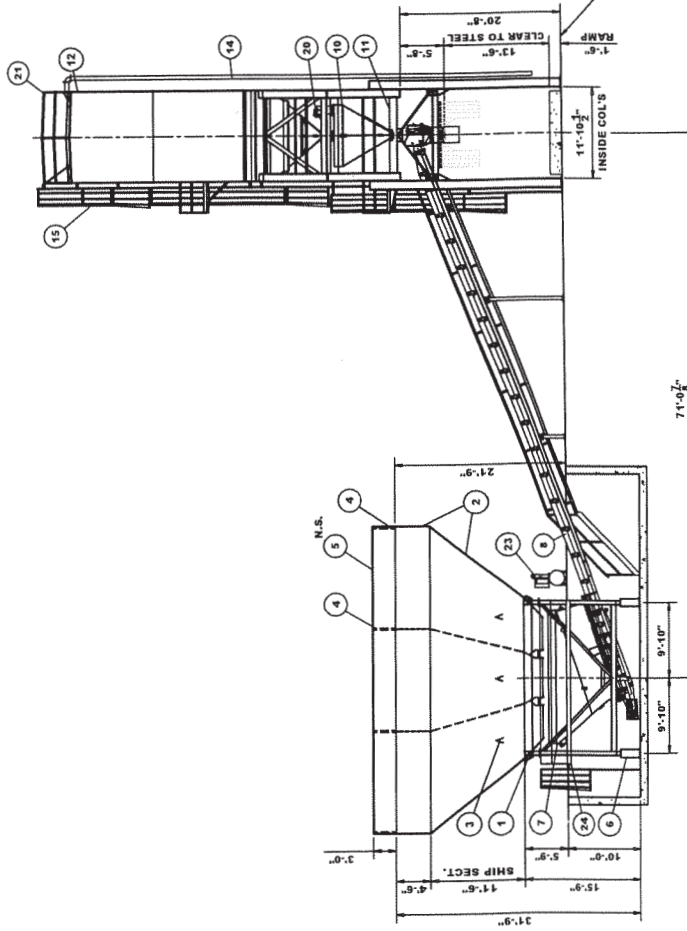
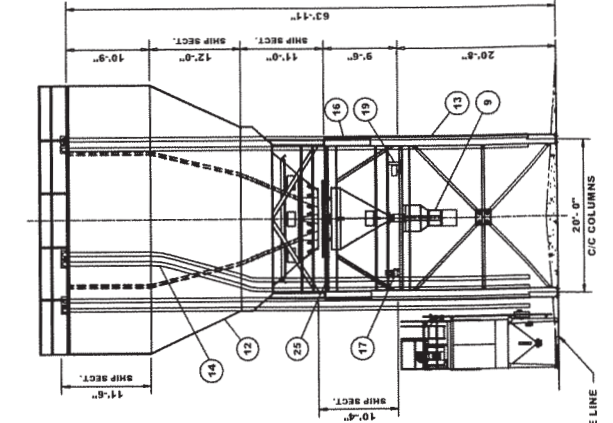
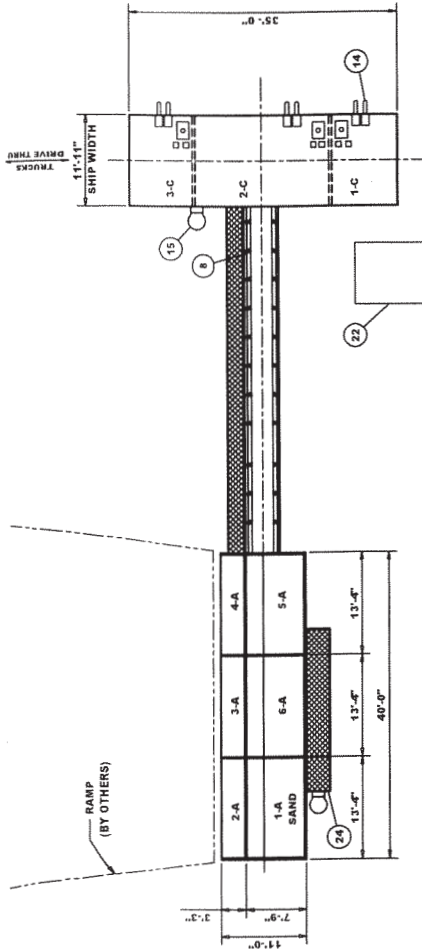

FOR PLANT ANCHOR BOLT PLAN SEE DWG. 4A-254700.

<p>ERIE STRAYER CO. 1851 Rudolph Ave. Erie, PA 16502 Phone: (814) 456-7001 Fax: (814) 452-3422 Website: www.eriestrayer.com</p>		<p>PLANT POWER 575V - 3PH - 60HZ CONTROL POWER 120V - 1PH - 60HZ</p>		<p>ERIE STRAYER CO. LOW PROFILE TRANSIT MIX PLANT GENERAL ARRANGEMENT WESTERN CONCRETE PRODUCTS MPB-8518 1/8"=1'-0" 4A-254699-1</p>	
NO.	REVISION	DATE	BY	NAS	DATE
1	CHANGE WALKWAY ON BTC TO LH SIDE	10/22/2013	NAS	10/4/2012	
<p>REVISIONS / COMMENTS / DATE / DRAWN / CHECKED / APPROVED</p>					



ERIE STRAYER COMPANY

CONCRETE BATCH PLANTS TILT MIXERS BATCH CONTROL SYSTEMS
ENVIRONMENTAL CONCRETE RECLAIMERS CRANE ATTACHMENTS

CONTRACT

WESTERN CONCRETE PRODUCTS

1920 Park Avenue
Brandon, Manitoba R7B 0R9

Contract No. MPB-8518

Drawing No. 4A-254699

Date: October 4, 2012

Representative: David A. Karn

Erie Strayer Company hereby offers to provide equipment and material in accordance with the specifications, terms and general conditions hereafter set forth and with any plans incorporated by reference herein.

LOW PROFILE TRANSIT MIX PLANT (MPB-11T)

Support Frame

Aggregate bin support frame
Support sills to grade
Shipping brackets

Aggregate Bin

255 cu yd (344 ton US) (225 cu yd water level) aggregate bin, pattern A-222 (CPMB rated). (Note: 245 cu yd predicted heap capacity with front end loader.)

Two welded bin extensions

Aggregate bin fabricated from 1/4" plate

Removable end and partition extensions

Weld-in 1/2" polyurethane liners installed on sloped surfaces of bin hopper subject to wear

Six (12" x 54") individual air operated radial charging gates with factory mounted air cylinders

Solenoid valves, filter and regulator with gauge factory mounted on steel support on aggregate support

Factory wiring from solenoid valves to junction box mounted on aggregate support frame

Air hose and fittings factory installed from solenoid valves to gate cylinders

Low level indicators with covers in each compartment

Heating register provided in each compartment supplied for Polarmatic heating system (Polarmatic heating system furnished by others)

Silent rotary turbine solenoid valve controlled air vibrator factory installed on bin hopper section of each aggregate compartment

Aggregate bin hopper gate service platform with expanded metal decking, handrails and toeplates on one side of bin

Ladder with safety cage from grade to aggregate bin hopper gate service platform



P.O. BOX 1031 ERIE, PENNSYLVANIA 16512-1031
1851 RUDOLPH AVENUE ERIE, PENNSYLVANIA 16502-1940
TELEPHONE (814) 456-7001 FAX (814) 452-3422
E-MAIL sales@eriestrayer.com

Aggregate Batcher

AB4B-15 cu yd aggregate batcher (CPMB rated)

Batcher constructed of 1/4" plate

Weld-in 1/2" polyurethane liners installed on sloped surfaces subject to wear

Batcher mounted from load cell scale system consisting of four load cells, load cell junction box and interconnecting cable (**load cell indicator by others**)

Test weight hangers factory installed on batcher (four hangers)

Silent rotary turbine solenoid valve controlled air operated vibrator factory installed on rear of batcher

Two independently air operated solenoid valve controlled discharge gates with inching controls

Solenoid valves factory mounted on the steel support with the aggregate bin charging solenoids

Factory wiring from solenoid valves to junction box with aggregate bin wiring

Air hose and fittings factory installed from solenoid valves to the air vibrator and gate cylinders

Batch Transfer Conveyor

36" x 78'-10 3/4" batch transfer conveyor

40 HP electric motor and gear drive with backstop

Shaft mounted drive reducer with backstop

Expanded metal drive and tail guards

Channel frame

Lagged head pulley

Self cleaning tail pulley

Troughing and return idlers

Telescopic screw takeup assemblies

Conveyor belt with sufficient length for field vulcanization (**vulcanization by others**)

Skirtboards with adjustable rubber flashing factory installed the full length of the batcher discharge gates

Conveyor supports

Hinged galvanized belt covers

Emergency stop cords on one side of conveyor

Startup warning horn with time delay for starting of conveyor (horn located at tail of batch transfer conveyor)

Walkway with expanded metal decking, handrails and toeplates on one side of conveyor to head section of batch transfer conveyor

Stairway with handrail from grade to batch transfer conveyor walkway located at aggregate unitized section

Cement Bin

P12-UPC3-2500 unitized cement bin, pattern C-111 (CPMB rated)

Cement bin construction

- Bin hopper section 11'-0": Perimeter 5/16" plate, internal dividers 1/4" plate
- Bin mid module 12'-0": All 1/4" plate
- Bin top module 10'-9": All 3/16" plate

Three compartments one with an approximate air volume of 5000 cu ft and a maximum capacity of 185 cu yd and two with an approximate air volume of 2500 cu ft and a maximum capacity of 92 cu yd

Double wall partitions with tell-tale openings at the bin bottom between compartments

Columns and bracing to grade

Handrails and toeplates for edges of cement bin roof

Manhole with cover in roof of each compartment
Top mounted high level and low level signals in each compartment with wiring to junction box
Top mounted emergency high level signal and overflow warning system consisting of control panel with timer, warning light and alarm for each compartment
Six air loading kits (two per compartment), each consisting of turbulence box, 5" piping to approximately 4' above grade and quick connector with dust cap
3" dust return line consisting of turbulence box and 3" piping to from dust collector platform to flyash compartment of bin
Solenoid valve controlled air pad aeration system for each compartment
Three WAM slide safety gates
Three 10" dia air operated butterfly charging valves
4" pipe cleanout with cap above each safety slide gate
Solenoid valves (Valvair Series) factory installed with the cement silo and batcher solenoids
Factory wiring from solenoid valves to junction box
Air hose and fittings for field installation from solenoid valves to charging valve actuators
Ladder with safety cage from cement batch platform to bin roof; ladder offset with rest platforms with handrails and toeplates so no single run of ladder exceeds 30'
Dust duct connection installed in roof of each compartment
Bolted access hatch in cement bin hopper section of each compartment

Unitized Cement Batching Section

Checkered plate batch platform decking
Ladder and safety cage from grade to batch platform
Checkered plate platform at top of cement batching platform for servicing cement bin discharge valves with ladder access from batch platform
Handrails and toeplates on edges of platforms

Cement Batcher

CB4-15 cu yd cement batcher (CPMB rated)
Batcher mounted from load cell scale system consisting of four load cells, load cell junction box and interconnecting cable (load cell indicator by others)
Test weight hangers factory installed on batcher
Solenoid valve controlled air pad aeration system installed in batcher cone
Solenoid valve controlled air vibrator factory installed on the cone section of the batcher
10" dia air operated butterfly discharge valve with inching controls
Solenoid valve controlled air actuator with valve position indicator factory mounted on the discharge valve
Solenoid valves with factory mounted with the cement bin solenoids
Inlet and vent flanges factory installed in batcher roof
Neoprene connections for field installation between charging valves and batcher inlet flanges
Solenoid valves factory mounted on steel support
Factory wiring from solenoid valves to junction box with cement bin wiring
Air hose and fittings factory installed from solenoid valves to air vibrator and discharge valve actuator
Cement batcher filter vent with 36 sq ft of cloth area and reverse pulse jet bag cleaning system
Bolted access cover

Truck Charging Chute

Truck charging chute factory installed in cement travel frame

Weld-in 1/4" AR400 abrasion resistant steel liner plates factory installed in the aggregate section of the chute

Constant tension polyurethane belt wiper

Separate cement chute with flexible boot to keep cement separate from the aggregates and water to entry into the truck chute

Water nozzle to direct water downward into the truck chute

Six 3/4" admix connections in water nozzle

Flexible truck chute boot

13'-6" clearance from 1'-6" ramp to steel

Water Meter

3" turbo water meter with electronic scalable transmitter mounted on cement batcher unitized section

Hot and cold water service

One pulse per gallon

Meter stand

Flanges

Strainer

Air operated water control valve

Solenoid valve mounted on control valve

Factory wiring from solenoid valve to junction box with aggregate bin wiring

Air hose and fittings factory installed from solenoid valve to the water valve actuator

Water piping from water meter to truck charging chute water nozzle

Plant Motor Control Panel (CSA Approved)

Motor control panel mounted on aggregate support frame

NEMA 4 enclosure

Disconnect circuit breaker

Control transformer

Fuses and across-the-line motor starters with overload heaters for

1 - 40 HP batch transfer conveyor

1 - 30 HP air compressor

1 - 7 HP aeration blower

Power wiring in flexible conduit for field connection for all motors

Air Compressor

30 HP Atlas Copco air compressor

Air receiving tank

Desiccant air dryer

Air hose and fittings furnished for field installation from normal air compressor location adjacent to aggregate bin to solenoid manifold assemblies

Aeration Blower

7 HP aeration blower mounted in cement unitized batching section platform

Solenoid valves mounted on manifold assembly

Factory wiring from solenoid valves to junction box mounted in unitized cement batcher section

Air hose and fittings installed from solenoid valve to batcher and silo aeration systems

Air hose and fittings furnished for field installation from solenoid valves to two compartment auxiliary silo aeration system

Main Junction Box

Main junction box for field mounting in control room

NEMA 4 enclosure

Wiring in flexible conduit furnished for field connection from plant junction boxes and motor control panel to main junction box

Control system is furnished by others

Load cell indicators by others

Wiring from control system to main junction box is by others

Model CP-7500 Dust Collector

C&W-CP-7500 dust collector

Single compartment dust collecting enclosure with:

- 1694 sq ft of 8" diameter washable polyester drop-in cartridges
- Reverse pulse jet cleaning mechanism
- Hinged top for easy access
- Catwalks, guard rails and ladders

Lower frame with structural steel support, pyramidal collecting hopper and butterfly discharge valve

7,500 CFM blower with 15 HP TEFC electric motor

16" snap duct blast gate

Drive Thru Vis-A-Load dust shroud with telescoping lift frame

Includes rubber boot attached to shroud which is lowered into truck charging hopper while truck is being loaded

Easy-up snap-together ductwork to cement bin roof for three compartments and to drive thru shroud with blast gates in ducting to truck shroud to divert air when hot water is used in the winter

Dust recycling system with 10 HP blower and 3" piping to return dust to flyash compartment

Control panel with main switch, control transformer, motor starters and wiring

Plant Erection**SCOPE OF WORK:****I. ERECT:**

Erector will supply tools, tackle, and labor to erect the plant as described in the drawing and as follows:

1. Aggregate bin unit with built-in batcher and gates.
2. Aggregate bin extensions with bolt on heap plates.
3. Aggregate batch transfer conveyor with walkway on one side.

4. Cement bin with support structure, unitized cement batcher section, three section bin, external fill pipes, and aeration blower. Installation of platforms, ladders, and handrails is included.
5. Central dust collector with ductwork and truck shroud. Connection to the cement bin is included.
6. Erector will install one (1) water hose from the meter to the truck charging chute.

II. NOTES:

A. General Notes:

1. The customer must provide adequate access to the erection site for erection personnel and equipment at all times. The erection is based on having access directly adjacent to the foundations for setting up cranes and offloading equipment. Time spent waiting for access to the site or additional lifting equipment charges due to inadequate site conditions will be billed as a contract extra at \$70.00 per man-hour plus any additional rental equipment charges.
2. The customer shall be responsible for supplying all cranes, manlifts, and other lifting equipment needed to complete the job (lifting equipment requirements to be determined by erector). This quote is based on lifting equipment being available when requested by erection personnel, time spent waiting for lifting equipment will be billed as a contract extra at \$70.00 per man-hour plus any additional rental equipment charges.
3. The erection is based on one mobilization. Additional trips to the jobsite will be billed as a contract extra.
4. Round trip airfare for erection crew for one mobilization is included.
5. The erector will use their own open shop labor. In the event labor problems arise due to demands of local trade unions, or others, and the customer is unable to resolve the problem without compromising the erector's operation, the following will apply: The erector will discontinue its operation and bill for work completed. The erector will remove its manpower and equipment from the job site and be released from further responsibility. The erector will cooperate with the customer in a manner to minimize disruption of the work.

B. Items NOT Included:

1. Hook-up and calibration of scales.
2. Modification / repairs to existing or new equipment.
3. Vulcanized belt splices.
4. Foundation work.
5. Retaining walls.
6. Installation of any equipment not listed above.
7. Piping work.
8. Fasteners and hardware.
9. Construction of permanent building structures.
10. Certified prints or engineered drawings.
11. Site work.
12. Permits.
13. Insulation work.
14. Disposal of construction debris and trash. Customer must provide trash cans / dumpster.
15. Freight or transportation of equipment.
16. Unloading of equipment that arrives before or after the scheduled construction period. Special trips to the job site to unload equipment are **NOT** included.

Notes

Equipment conforms to the Standards of the Concrete Plant Manufacturers Bureau (CPMB), the Plant Mixer Manufacturers Division (PMMD) and the Control System Manufacturers Division (CSMD) of the National Ready Mixed Concrete Association (NRMCA) as noted.

ERIE Strayer Company will furnish a factory serviceman for a period not to exceed **10 days** to assist the operating personnel in the final connections of the automatic equipment, to calibrate the control system, and to assist in the initial operation of the equipment. This feature includes **two round trips** from the factory to the jobsite, along with travel and living expenses. Any time in excess of the foregoing will be chargeable and invoiced at standard rates. In order to take advantage of reduced air fares, the customer must notify ERIE at least seven days in advance of when service is required. Customers requesting service with less than seven days notice will be required to pay the premium on the transportation costs.

Additional service is available at the prevailing rate plus travel and miscellaneous expenses marked up 15% to cover administration. Service days are calculated from the time the service man leaves the factory until he returns to the factory (portal to portal).

Control power: 120/1/60
Plant power: 575/3/60

The use of flexible power cables and/or flexible, multi-conductor cables for permanent installations is not permitted by the National Electrical Code (N.E.C.), unless they are suitably protected against physical damage (protective equipment is by others), and this proposed use in no way constitutes a guaranty of code compliance on the part of Erie Strayer Company.

Even in those cases where use of flexible cables is permitted by the N.E.C., local codes may prohibit their use; therefore, local code requirements should be determined prior to the purchase and use of flexible power cables and/or flexible, multi-conductor control cables.

Plant is painted **ERIE Gray**.

No access ladders, stairs, stairways, walkways, handrails, guards or enclosures are included with this contract unless specifically outlined.

Balancing, calibration and sealing of scales are by others.

State, Local or Federal OSHA Safety Regulations may apply to Erie Strayer Company products depending upon the application of the equipment and its place of installation. Erie Strayer Company, therefore makes no representations that the equipment subject of this contract meets all State, Local, or Federal OSHA Safety Regulations.

Erie Strayer Company will upon request quote the price of any equipment specified by the user and believed by it to be required by State, Local or Federal OSHA Safety Regulations.

Two sets of manuals are provided.

WESTERN CONCRETE PRODUCTS, LTD.
 1920 Park Ave.
 Brandon, MB R7B 0R9
 Canada

Quotation No. LM-12092012_1500G

Date: September 12, 2012

Attn: Mr. Rick Golletz

We are pleased to offer you the TURBOMATIC heating system model **PME-STD 1500 G** in accordance with the prices, terms and other conditions set forth in this letter.

TECHNICAL DATA

- type PME-STD 1500 G
 - capacity 1500 kW
 - fuel natural gas
 - interfaces/connections
 - natural gas min. 1.5 bar(g), max. 150 m³n/h
 - main electrical supply 3~ 575 V, 60 Hz, 150 A
 - cold water 4-10 °C, DN 50
 - compressed (instrument) air 7-8 bar(g)*
- * note! compressed (instrument) air supplied from the batching plants compressed air system

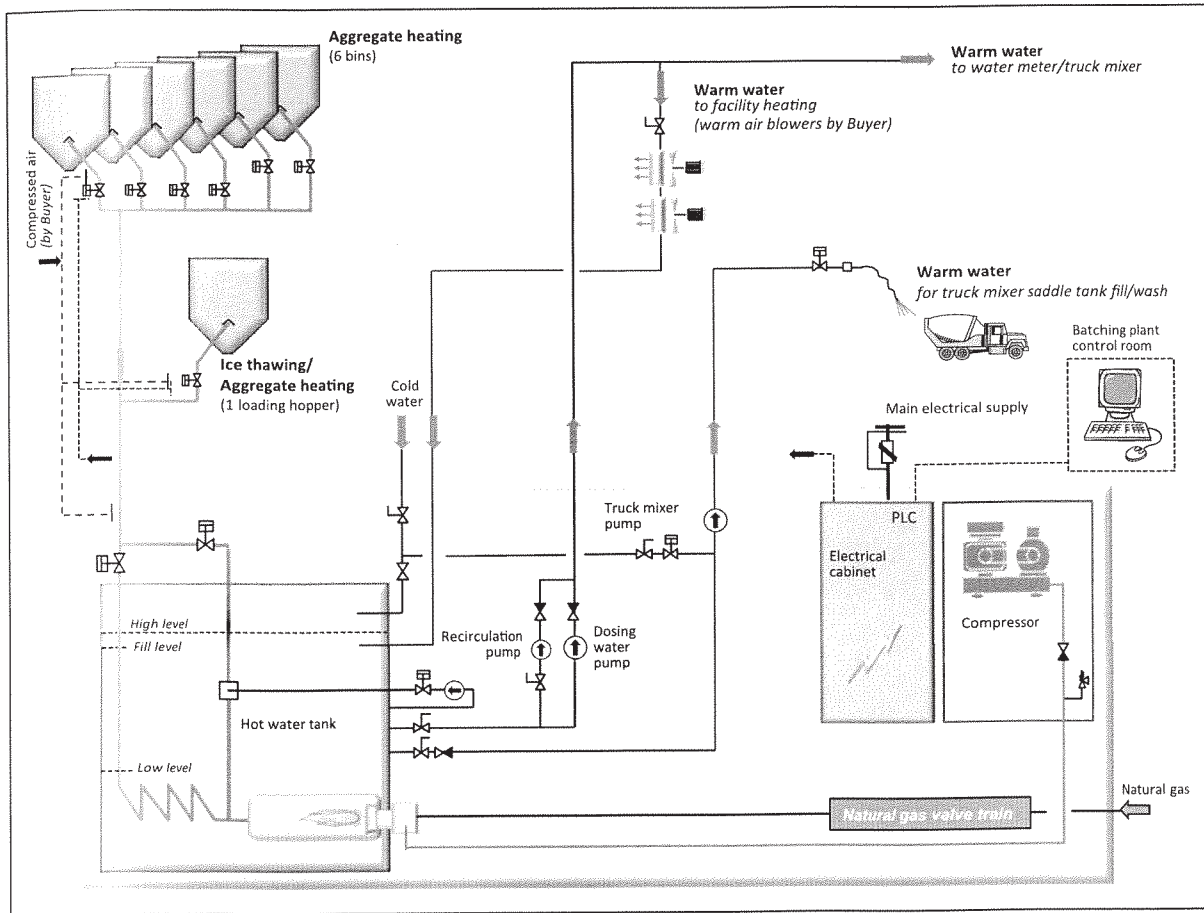

TURBOcontainer

TURBOMATIC-thermal energy unit built in a used 20' sea container:

- main dimensions
 - length x width x height 6058 x 2438 x 2591 mm
 - weight (empty) appr. 8 000 kg
- painting to be specified (www.ralcolor.com)
- insulation
 - floor polyurethane (sprayed), 30 mm
 - walls and roof 50 mm mineral wool, steel cassettes
- floor checkered plate (walkways)
- doors side access door with air inlet grid
 double doors for maintenance at end of container
- lighting & electrification
 - fluorescent lights
 - electrical sockets for maintenance purpose
- electrical heater (warm air) approx. 3 kW, for stand-by operation

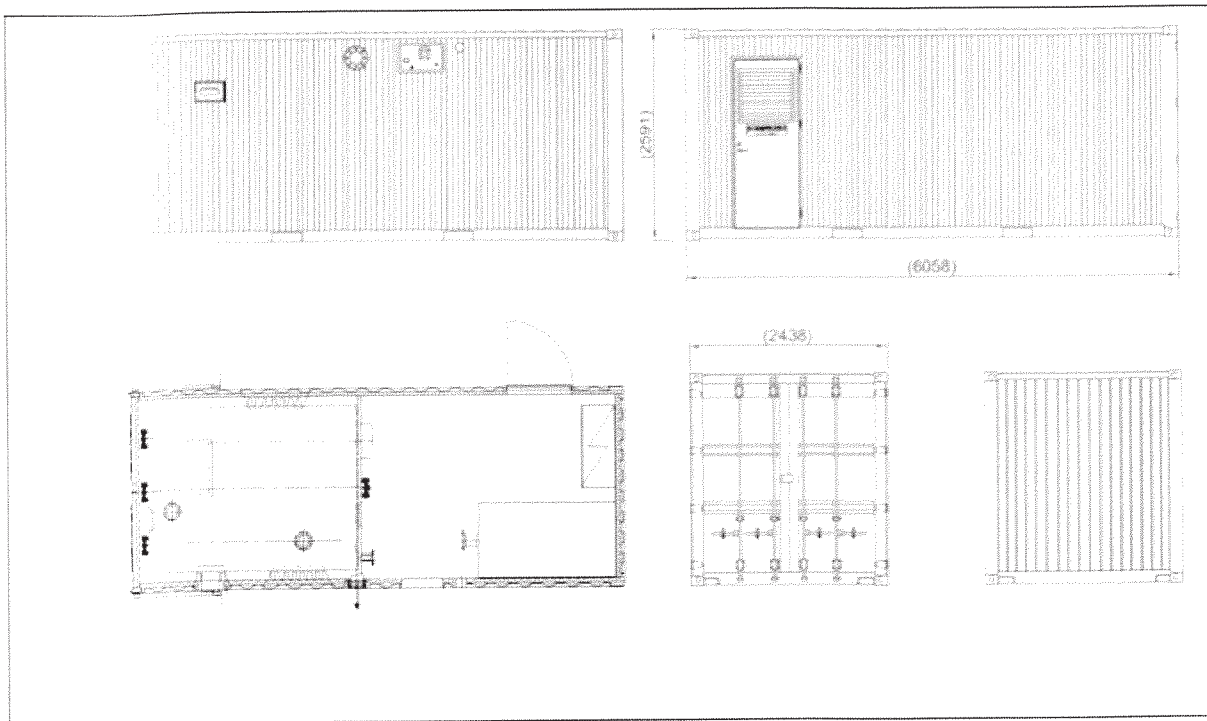

TURBOcontainer layout (A2)

note! layout, showing the location of the side access door and the piping exit direction

TURBOgas, -steam and hot water systems

TURBOgenerator

- Hot water tank
 - volume 8000 liters
 - material AISI 304 or equal
 - insulation front and rear wall, roof 50 mm mineral wool
side walls 100 mm mineral wool
- Combustion chamber
 - material AISI 316L or equal
- Heat exchanger (flue gas / water)
 - capacity 1 325 kW
 - material AISI 316L or equal
- TURBOsteam generator
 - material AISI 316L or equal
- TURBOsteam pump
- Hot water tank electrical heaters (for stand-by operation)
 - capacity 2 x 30,000 BTU/h
 - thermostat-control

TURBOgas/-steam piping (installed inside TURBOcontainer)

- pipe material AISI 316L or equal
- valves for selection of heating mode (aggregate/water-heating)
 - type butterfly
 - material AISI 316 or equal (internal parts)
 - number 2 pcs

Dosing water pump

- volume flow 800 l/min
- head (preliminary) 21 m
- motor size (preliminary) 7.5 kW

Recirculation pump

- volume flow 50 l/min
- head (preliminary) 20 m
- motor size (preliminary) 0.55 kW

The recirculation pump is utilised to circulate water through the dosing water pipe line and back to the hot water tank. *In this manner the dosing water pipe will always be filled with warm water ensuring that each batch will receive water at the desired (warm) temperature. **note!** warm air blowers can be connected to this circuit for heating of the batching plant facilities.*

Dosing water/recirculation piping (installed inside TURBOcontainer)

- material AISI 316L or equal (dosing water piping)
copper (recirculation piping)

Natural gas system

Burner

- fuel natural gas
- volume flow (max) 150 m³n/h
- equipment flame detector

Natural gas piping and equipment *(installed inside TURBOcontainer)*

- connection flanged connection
- piping material carbon steel (painted)
- appliance manual shut-off valve
- pressure gauge, inlet
- pressure regulator
- pressure gauge, outlet
- low gas pressure switch
- high gas pressure switch
- safety shut-off valve with proof of closure
- pressure gauge, burner
- input flow control valves

Combustion air system

Compressor

- type ROOTS
- volume flow (max) 2000 m³n/h
- pressure (max) 0,5 bar(g)
- motor size 45 kW
- equipment variable frequency drive
sound attenuation

Combustion air piping

- material carbon steel
- surface treatment painting
- equipment safety valve,
back-pressure limit switch

Electrification

Electrical cabinet (OK1)

- connection to main electrical supply
- installed inside TURBOcontainer
- dust protected
- TURBOMATIC-manual operation possibility for maintenance purposes
- manufactured in accordance with applicable safety rules and regulations

Cabling

- electrical and control cables installed in cable trays (inside TURBOcontainer)

Instrumentation and controls

PC-user interface *(PC shipped loose for installation by Buyer in control room)*

- PC with 17" monitor, mouse and connecting cables
- Programmable logic controller (PLC)
- PLC installed in electrical cabinet OK1

Software

- TURBOMATIC-software factory installed and tested

Instrumentation and safety equipment

- water temperature
 - low water level
 - high container temperature
 - high TURBOgas temperature
 - burner failure
 - low pressurized air pressure
 - high combustion air pressure
-

TURBOMATIC – Additional Equipment **Pos 2.0**

Aggregate heating _____ pos 2.1

Loader hopper and bin valves are controlled automatically from the PC user interface of the TURBOMATIC control system.

Loader hopper and bin valves (*shipped loose; installation by the Purchaser*)

- | | |
|------------------------|---|
| • no of loader hoppers | 1 pcs |
| • no of bins | 6 pcs |
| • no of valves | 7 pcs |
| • type/material/size | butterfly /AISI 316 (internals) / DN 125 |
| • equipment | pneumatic actuator, limit switch, control valve |

Batching plant facility heating _____ pos 2.2

The batching facilities can be heated by pumping warm water from the TURBOMATIC's hot water tank with the recirculation pump to warm air blowers. The cooled water is returned to the hot water tank (*note! warm air blowers by the Purchaser*).

Truck mixer wash/fill system _____ pos 2.3

Warm water is pumped with a separate wash/fill pump directly from the TURBOMATIC's hot water tank. The desired water temperature is set with manual valves.

Piping

- | | |
|------------|---------------------------|
| • material | copper/AISI 316L or equal |
|------------|---------------------------|

Wash/fill pump

- | | |
|----------------------------|-----------|
| • volume flow | 150 l/min |
| • head (preliminary) | 30 m |
| • motor size (preliminary) | 1,5 kW |

Instrumentation (*installed inside TURBOcontainer*)

- local temperature gauge

START-UP and COMMISSIONING, TRAINING **Pos 3.0**

Start-up and commissioning, training includes one (1) visit at a point in time informed by the Purchaser and agreed upon by both parties. Additional visits will be charged for in accordance with Polarmatic's, at the time, applicable price list. The Purchaser is responsible for the accommodation (hotel etc.) costs.

A project acceptance document will be prepared and signed by both Parties upon successful start-up and commissioning.

Training for Purchasers's operating and maintenance personnel (1-3 persons) during the start-up and commissioning at site.

Operating and Maintenance instructions.



**WESTERN
CONCRETE**
PRODUCTS

1920 Park Avenue

Brandon, Manitoba R7B 0R9

Telephone (204) 728-2240

Fax (204) 725-3762

Schedule for Stages of the Development

June 1 2012- February 22 2013

Planning and Research into the new plant and systems

July 2012

Site Selection

July 2012

Site Assessment for Engineering/ soil analysis

June 1 2012 – October 1 2012

Plant Machinery Competition and Selection

October 2012 – December 30, 2012

Plant and Site Design

January 1, 2013 – April 7th, 2013

Plant Designs to CAD to Engineered Plans

Structural/ Electrical/ Mechanical Engineered Drawings finalized April 7, 2013

January -March 2013

Prepare and File Environmental Application

April 7 – April 30th, 2013

Final Pricing on Project

May – June 2013

Apply for Construction Permits/ Site Preparation/ Order all Equipment

July 1, 2013

Start Foundation Construction

September 1 – 15th, 2013

Erect Plant

September –December 2013

Complete Construction around the Erected Plant Structure

January – March 2014

Complete all Construction and attempt initial Commissioning

April 1 – May 30th, 2014

Operate out of the New Facility

Finish Site Construction

September – November

Decommission the Old Concrete Plant

Rehabilitate the old site to a renewed Commercial Space



ENVIRONMENTAL EMERGENCY PROCEDURE

UNAUTHORIZED OR ACCIDENTAL DISCHARGE TO WATER, GROUND, OR AIR

Use the following for all unauthorized or accidental discharges/spills to water, ground, or air. Examples include: spill of slurry of process water, cementitious blow-out, chemical or petroleum spills.

1. Perform spill emergency response procedures only if you do not put yourself or anyone else at risk
- ***Always wear appropriate Personal Protection Equipment (PPE) such as goggles, gloves or respirators when dealing with unknown or harmful substances**
2. Locate source of discharge or spill
3. Refer to Material Safety Data Sheet (MSDS) for the product that has been discharged or spilled. It will identify key hazards and emergency procedures to be followed
4. If the spill is too hazardous to contain, it may be necessary to evacuate the area. Barricade the perimeter of the danger zone to prevent untrained or unauthorized personnel from entering the area
5. Control the discharge or spill by minimizing to the flow (shut off valves, right overturned containers, etc.)
6. Confine the spill or discharge by using absorbent booms, or other materials such as sand to build a containment berm
7. Soak up excess discharge with absorbent pads or sand
8. Continue to use safe handling procedures when handling saturated absorbent pads
9. Report all spills to supervisor
10. Take care to prevent unauthorized discharges or spill from entering bodies of water, including ditches, streams, storm or sanitary sewers



ENVIRONMENTAL EMERGENCY PROCEDURE

In the event of an Environmental Emergency, the following procedures shall be followed to alert the proper authorities. An Alert is necessary whenever spills exceed the Legal Reportable Quantities listed below. The minimum reportable quantities below apply to spills and/or discharges onto land or into the air. **If the spill or discharge is into water, it must be reported to the authorities regardless of quantity.**

MINIMUM LEGAL REPORTABLE QUANTITIES

SUBSTANCE	AMOUNT/VOLUME	SUBSTANCE	AMOUNT/VOLUME
Diesel Fuel	100 Litres or more	Truck Washing Acid	5 Litres or more
Gasoline	100 Litres or more	Caustic Substances	5 Litres or more
Propane	Sustained Release of more than 10 minutes or poses an immediate danger to public safety	Asphalt Cement	50 Litres or more
Anti-Freeze (Ethylene Glycol)	50 Litres or more	Portland Cement	100 Litres or more
Hydraulic & Lubricating Oils	50 Litres or more	Fly Ash	50 Kg or more
Waste Oil (Hydraulic or Lubricating)	50 Litres or more	Concrete	50 Kg or more
Coalescing Agent	50 Litres or more		

***If a substance is not listed, report it regardless of the amount or volume

Substances spilled or discharged onto an engineered pad, surface, or floor (concrete, asphalt, or compacted clay) and cleaned up, **DO NOT** require external reporting if properly contained.

ENVIRONMENTAL EMERGENCY CONTACTS

MB Conservation 24 hour Environment Accident Reporting	1-204-944-4888
Canutec 24 Hour Hotline (TDG involvement)	*666 on cell phone or 1-613-996-6666
Federal Emergency Response	1-800-889-8852
Department of Fisheries and Oceans (Dauphin, MB - 8:00am - 4:00pm)	1-204-622-4060
Environment Canada	1-204-984-6203



ENVIRONMENTAL OPERATING PROCEDURE

ROUTINE MAINTENANCE

DUST CONTROLS

1. The bag house consists of several hanging cloth bags which act as a filter to entrap any air-borne cementitious particles before they can be released into the atmosphere. The bag house is activated by the batcher, and automatically drops the collected material from the filters back into the silo. The bag house and filters are inspected and cleaned monthly.
2. Dust emitting from the truck loading area is controlled by fine tuning the batching sequence so as to deliver a smooth, controlled flow of raw material into the mixer with a combination of water addition to control dust emissions
3. Fugitive source dust emissions: Dust emitting from traffic areas is minimized by dust suppression using water delivered via trailer and spray bar