

Environment Act Proposal Form



Name of the development: Lafarge Dawson Road Ready Mix	
Type of development per Classes of Development Regulation (Manitoba Regulation 164/88): Class 1	
Legal name of the applicant: Lafarge Canada Inc.	
Mailing address of the applicant: 135 Industrial Road Contact Person: Krista Meneghetti City: Oak Bluff Province: Manitoba Postal Code: R4G0A5 Phone Number: (403) 829-3052 Fax: email: Krista.Meneghetti@lafarge.com	
Location of the development: 49.887265, -97.093609 Contact Person: Greg Suderman Street Address: 210 Dawson Road Legal Description: Lot 1, Plan 43094 City/Town: Winnipeg Province: Manitoba Postal Code: R2J0S6 Phone Number: (204) 391-2631 Fax: email: greg.suderman@lafarge.com	
Name of proponent contact person for purposes of the environmental assessment: Krista Meneghetti	
Phone: (403) 829-3052 Fax:	Mailing address: 300, 115 Quarry Park Road S.E., Calgary, AB. T2C 5G9
Email address: krista.meneghetti@lafarge.com	
Webpage address: www.lafarge.ca	
Date: 2023/01/24	Signature of proponent, or corporate principal of corporate proponent:  Printed name:

PRINT

RESET

A complete **Environment Act Proposal (EAP)** consists of the following components:

- Cover letter**
- Environment Act Proposal Form**
- Reports/plans supporting the EAP** (see "Information Bulletin - Environment Act Proposal Report Guidelines" for required information and number of copies)
- Application fee** (Cheque, payable to Minister of Finance, for the appropriate fee)

Per Environment Act Fees Regulation (Manitoba Regulation 168/96):	
Class 1 Developments	\$1,000
Class 2 Developments	\$7,500
Class 3 Developments:	
Transportation and Transmission Lines ..	\$10,000
Water Developments	\$60,000
Energy and Mining	\$120,000

Submit the complete EAP to:

Director
Environmental Approvals Branch
Manitoba Environment, Climate and Parks
1007 Century Street
Winnipeg, Manitoba R3H 0W4

For more information:

Email: EABDirector@gov.mb.ca
Phone: (204) 945-8321
Fax: (204) 945-5229
https://www.gov.mb.ca/sd/permits_licenses_approvals/eal/licence/index.html

Please contact Greg Suderman at 204-391-2631 for credit card payment information

Internal Use Only	
\$1,000.....C1	B-02
\$7,500.....C2	B-02
\$10,000....TT	B-02
\$60,000....WD	B-02
\$120,000...EM	B-02



ATTN: Director, Environmental Approvals Branch

Manitoba Sustainable Development
Environmental Approvals
2nd floor, 123 Main Street
Winnipeg, MB
R3C1A5

January 24, 2023

Dear Director,

Lafarge Canada Inc. is applying for a Class 1 Environmental Permit, in order to continue to operate a concrete batch plant. This concrete plant is intended to permanently operate year-round. The Site is currently operational and has been operating since approximately 1977.

Please find enclosed a copy of the proposal form, and the required Environmental Assessment Report.

Should you have any questions in regards to this proposal please contact Krista Meneghetti at 403-829-3052 or by email at krista.meneghetti@lafarge.com.

Sincerely,

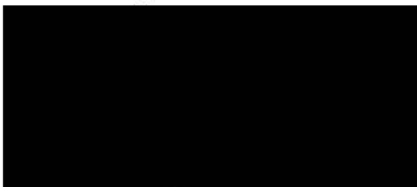

Krista Meneghetti
Manager, Sustainability and Environment
Lafarge Canada Inc.



DEVELOPMENT ENVIRONMENTAL ASSESSMENT REPORT

Dawson Road Concrete Batch Plant

210 Dawson Road

January 2023



TABLE OF CONTENTS

1. EXECUTIVE SUMMARY 1

2. INTRODUCTION AND BACKGROUND 2

 2.1. PRODUCTS AND SERVICES..... 2

 2.2. SITING 2

3. ENVIRONMENTAL EFFECTS OF PROPOSED DEVELOPMENT 3

 3.1. LAND 3

 3.2. WATER 3

 3.3. POLLUTION AND HAZARDOUS WASTES..... 3

 3.3.1. CHEMICALS AND HYDROCARBONS 3

 3.3.2. DUST 3

 3.3.3. WATER IMPACTS 4

 3.3.4. SOCIO-ECONOMIC IMPACTS 4

4. MITIGATION AND RESIDUAL ENVIRONMENTAL EFFECTS 5

 4.1. ENVIRONMENTAL MANAGEMENT 5

 4.2. POLLUTION AND HAZARDOUS WASTE 5

 4.2.1. CHEMICALS AND HYDROCARBONS 5

 4.2.2. EROSION AND DUST CONTROL 5

 4.2.3. WATER 6



LIST OF APPENDICES

APPENDIX A:	PLANT SPECIFICATIONS
APPENDIX B:	SITE DESCRIPTION
APPENDIX C:	CHEMICALS AND STORAGE VOLUMES
APPENDIX D:	MRMCA CONCRETE CERTIFICATION STANDARD

1. EXECUTIVE SUMMARY

Lafarge Canada Inc. is requesting an environmental license for a permanent concrete batch Plant that is located in Winnipeg, Manitoba. The site is located at 210 Dawson Road. The site is currently owned and operated by Lafarge. The purpose of the facility will remain the same and is intended to create concrete products for the City of Winnipeg and surrounding area in order to meet the tender requirements for contracts in the area. Environmental effects are expected to be low to none in areas of water, dust, erosion, wildlife impact and pollution with appropriate mitigation efforts.



2. INTRODUCTION AND BACKGROUND

Lafarge Canada Inc. (Lafarge) is requesting an environmental license for a permanent concrete batch plant. The purpose of the facility is to meet the tender requirements for various contracts throughout the Winnipeg area. The Site is fully constructed and has been operating at this location since approximately 1977.

2.1. Products and Services

Concrete services rendered will be produced via a permanent BMH 9 m³ RollMaster Mixer. The mixer has a permanent building built around it. The concrete batch plant will produce concrete at a maximum rate of 120 m³ per hour and has updated batch plant technology including a new commandbatch E-Z panel, low level detectors, and two C&W central dust collector that services the silo's and the plant load points. Material inputs for the product will include cement, lime stone, sand admixtures and water. See Appendix A for plant specifications.

2.2. Siting

The Site is currently constructed and operating. It is not anticipated that any changes will be made to the layout of the Site. A site plan showing the equipment and the layout of the Site is included in Appendix B. The land use to the north, east, west and south is currently zoned as Commercial/Industrial.



3. ENVIRONMENTAL EFFECTS OF PROPOSED DEVELOPMENT

3.1. Land

Effects arising from the use of the site depend on the makeup of the site itself, but can include soil compaction, silt erosion into nearby ditches and fugitive dust. The site is currently operating and the land is generally flat and has been graded with gravel. The surrounding land to the north, east, west and south is also industrial.

3.2. Water

Water used at the site for the purposes of production will originate from an City of Winnipeg water infrastructure. The nearest waterbody to the site is the Seine River located approximately 600 m west of the site. The nearest significant water body is the Red River located approximately 2.0 km west of the site. No other water bodies were identified near the Site.

3.3. Pollution and Hazardous Wastes

There are no hazardous wastes produced in the manufacturing of concrete.

3.3.1. Chemicals and Hydrocarbons

Diesel fuel will be used for the loader onsite. Potential effects could include a hydrocarbon or chemical spill on site, and air pollution in the form of greenhouse gases and particulate matter from the diesel generator.

Other chemicals used onsite will include admixtures for concrete batching including Mastersure Z260, Masterset AC534 and Masterpolyheed 980. All chemicals will be stored in individual containers, and in secondary containment. See Appendix C for a list of chemicals and storage volumes.

3.3.2. Dust

Point source dust pollution is a possible environmental effect from the production of concrete. Cement is a known source of $PM_{<2.5}$.

LAFARGE CANADA INC.

#300, 115 Quarry Park Road SE, Calgary, Alberta T2C 5G9
Phone: (403) 225-5400 Fax: (403) 278-2738
www.lafarge.ca



The gravel base pad under the concrete plant and other infrastructure is also a possible source of fugitive dust, and potential sediment erosion into nearby ditches. In cases of high fugitive dust potential, reduced traffic speed will be implemented on site, and water (or other dust suppressants) will be used as necessary to reduce dust levels.

3.3.3. Water Impacts

Concrete batching plants can be a source of potential water impacts due to truck washing and drum rinsing. Impacts could include siltation, high pH of 11+ and admixture chemicals. Truck washout is contained to a designated location onsite, so as to not cause adverse effects to the surrounding land or water.

3.3.4. Socio-Economic Impacts

Ready-mix plants have positive socio-economic impacts such as, employment, sub-contractor work, local material purchases and building local infrastructure. The risk for public safety concerns or human health risks are low as the site does not allow public access. There are no environmentally protected areas near the proposed site or heritage sites.



4. MITIGATION AND RESIDUAL ENVIRONMENTAL EFFECTS

4.1. Environmental Management

Environmental management of the site will be consistent with all applicable federal, provincial and municipal laws and regulations. In addition, it will also meet the standards of Manitoba Ready Mix Concrete Association (MRMCA) concrete certification standard (see Appendix D) and Lafarge's internal Environmental Management System (EMS) to ensure the protection of environmental health.

4.2. Pollution and Hazardous Waste

4.2.1. Chemicals and Hydrocarbons

All hydrocarbons and chemicals on site will be stored in secondary containment and be inspected regularly. Employees are trained in spill response techniques and spill response equipment will be easily accessible both on site and in their vehicles as per Lafarge's EMS requirements and procedures.

No hazardous waste will be produced during production. Should an uncontrolled release of any admixture, hydrocarbon or other chemical occur on site it will be contained, cleaned up and removed immediately by a third party environmental disposal company. Clean up and disposal methods will be in compliance with Lafarge's EMS procedures and applicable hazardous waste legislation.

Should a diesel generator be required onsite, it will be appropriately maintained to operate as per the manufacturer's specifications.

A list of Chemicals that may be stored on the site are included in Appendix C.

4.2.2. Erosion and Dust Control

The type of base pad under the concrete plant is a possible source of fugitive dust and sediment erosion into nearby ditches. Appropriate grading and other environmental controls will be put



into place as needed to minimize these impacts. In cases of high fugitive dust potential, reduced traffic speed will be implemented on site, and water (or other dust suppressants) will be used as necessary to reduce dust levels.

Point source dust pollution is a possible environmental effect from the production of concrete. The plant will be equipped with engineered controls and dust suppression equipment. These engineered controls, along with regular maintenance and appropriate dust control procedures should allow for elimination, or a significant reduction of environmental effects.

Dust control will be monitored by site employees through maintenance and routine inspections. Should a dust release occur, Lafarge EMS work procedures will be followed to mitigate the impact and identify the cause.

Three meteorological stations are located near the site (St.Adolphe, Dugald and Stonewall), and as such will be monitored for potential weather hazards or storms which could cause adverse environmental effects at the site.

4.2.3. Water

The wash-out and wash-down water from the ready mix trucks is contained to a designated location onsite. Lafarge is currently trialing a new concrete admixture called Master Suna which is an admixture that is added directly to the drum of the ready-mix truck. It is a powdered polymer that gels the fresh concrete resulting in very rapid stiffening and significantly minimized cement hydration. It allows the potential washout to be recycled as aggregates and eliminates any potential liquid discharge or disposal to landfills.

APPENDIX A
Plant Specification

LAFARGE CANADA INC.

#300, 115 Quarry Park Road SE, Calgary, Alberta T2C 5G9

Phone: (403) 225-5400 Fax: (403) 278-2738

www.lafarge.ca

AGG

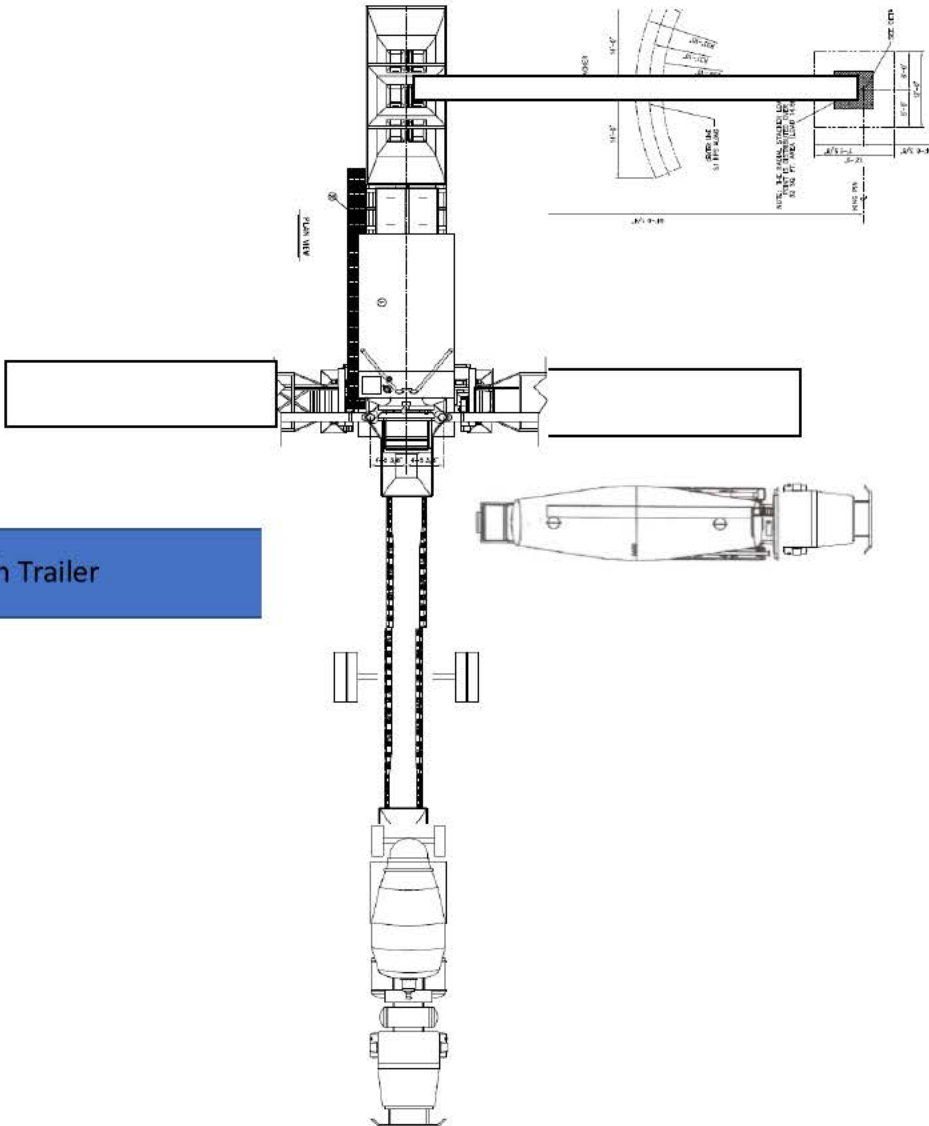
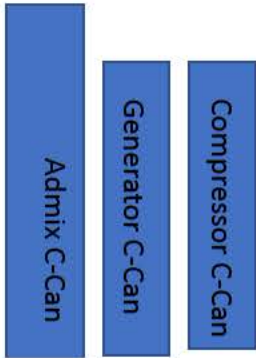

Batch Trailer

HT SERIES

ADAPTS TO YOUR WET BATCH NEEDS



HT PAIRED WITH HORIZONTAL SHAFT MIXER WITH RCC UPGRADE



SHT PAIRED WITH TWIN SHAFT MIXER



SHT PAIRED WITH A PORTABLE TILT MIXER

HT SERIES OPTIONS

- HYDRAULIC SELF ERECT
- FOLDING WALKWAYS & HANDRAILS
- AUTO DUST RECLAIM
- SHROUD UPGRADE
- WATER HEATER AND CHILLER
- WEIGHED WATER SYSTEM
- COMPUTER AUTOMATED OPERATING CONTROLS
- AIR COMPRESSOR UPGRADE
- DESICCANT AIR DRYER
- MANUAL OPERATING CONTROLS
- QUICK CONNECT PLUGS
- AERATION PAD UPGRADE
- WINCH FOR FOLDING LEGS
- AR OR POLY LINERS
- MOUNTED TRAILER JACKS
- LOGO PLACEMENT
- CONTROL TRAILER
- CENTRAL GREASE SYSTEM
- TIRE COVERS



CONCRETE BATCHING EQUIPMENT

P.O. Box 655141
Dallas, Texas 75265-5141

WWW.VINCEHAGAN.COM

1-800-354-3238 OR 214-330-4601



MADE IN THE U.S.A

HT • SHT • HTS SERIES



HT • SHT • HTS SERIES
HAGANATOR TRAVEL-ALL
SUPER HAGANATOR TRAVEL-ALL
HAGANATOR TRAVEL-ALL + SUSPENSION



- PATENTED TRUSS FRAME TRAVELS AS ONE LOAD OF FREIGHT
- NO CRANES NEEDED - OPTIONAL HYDRAULIC SELF ERECT
- CAN BE SET UP ON CONCRETE FOUNDATION OR STEEL PLATES
- IN-TRUSS DUST COLLECTION AVAILABLE
- MANUAL OR AUTOMATED BATCHING CONTROLS
- UP TO 400 YDS/HR (CENTRAL MIX)

WWW.VINCEHAGAN.COM



HT-SERIES BATCH PLANT - A TRUE LEGEND & LEGACY SINCE 1956



FIRST MOBILE BATCH PLANT

In 1956, Vince Hagan, founder of The Vince Hagan Company, began with an original idea. He designed and built the first fully mobile concrete batch plant. Over the years, this patented "Haganator" design has become an international icon for the mobile concrete industry. Today, The Vince Hagan Company is continuing to improve this original idea. By bringing together proven experience and the most current technology, we offer our customers the highest quality products and services available in the industry.

The HT-Series Haganator Travel-All is the most time-efficient and cost-effective full mobile concrete batch plant available today. The HT is completely mobile and travels as a single load of freight including dust collection, saving you transportation cost. At your job site, the plant can be fully erected and operational in less than four hours. All components are on board and the entire plant is pre-wired and plumbed for air and water. All plants tested at our factory to ensure trouble free start-up and operation.

- Plant mounted jet-pulse dust collection system
- Auto dust recycle system
- Up to 500 barrels of cementitious storage
- Up to 100 Tons of aggregate storage
- Complete hydraulic self-erect system
No cranes needed
- Multi-flight cement screw feeders up to 12"
- Deep trough transfer belt 24" to 48" wide
(Belt speed 380 ft./min. up to 650 ft./min.)
- 12 yard aggregate batcher
- 12 yard cement batcher
- Water batcher

HT-SERIES BATCH PLANT WITH HCA

WHAT IS SO UNIQUE ABOUT THE HT-SERIES HAGANATOR TRAVEL-ALL?

- FEWEST LOADS OF FREIGHT IN THE INDUSTRY
(DUE TO PLANT MOUNTED DUST SYSTEM)
- LARGEST CEMENT STORAGE IN THE INDUSTRY
- LARGEST AGGREGATE STORAGE IN THE INDUSTRY
- CAN BE SETUP IN UNDER 4 HOURS
- NO CONCRETE FOUNDATIONS REQUIRED - SETS UP ON STEEL PLATES OR TIMBER MATS (DEPENDING ON SOIL CONDITIONS)
- COMPLETELY ERECTED AND TESTED AT OUR FACTORY
- SHT SERIES EASILY ADAPTED TO A CENTRAL MIX OPERATION
- CAN SELF ERECT WITHOUT THE USE OF A CRANE

The Vince Hagan Company offers the highest quality products and services available. Our sales and engineering staff will guide you through the planning stages to ensure your company is purchasing the right equipment for the job. Our sales offices are located in Dallas, Texas. We have company service personnel who can travel directly to your job site and our tech support is available 24/7. Our goal is to provide the best service before and after the sale. A successful project begins with The Vince Hagan Company.

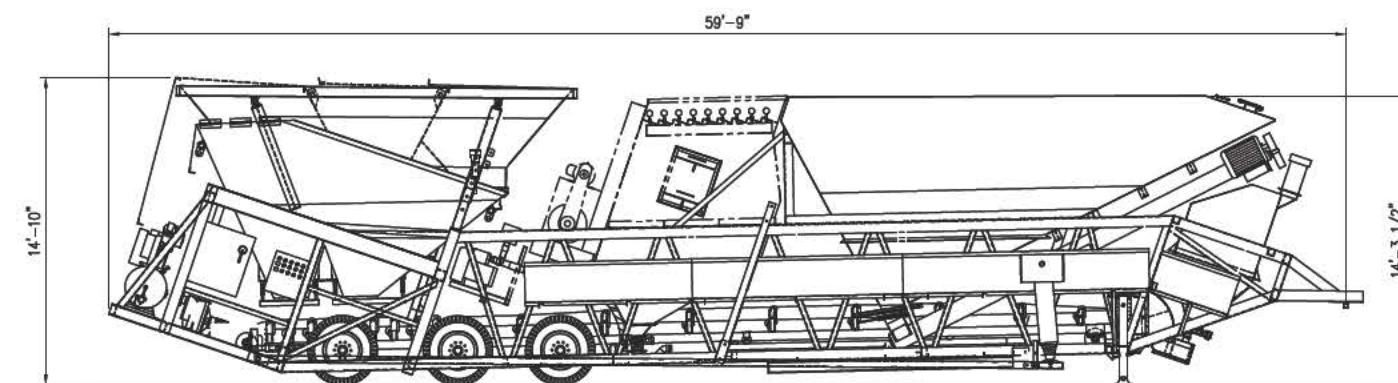

TRAVEL POSITION

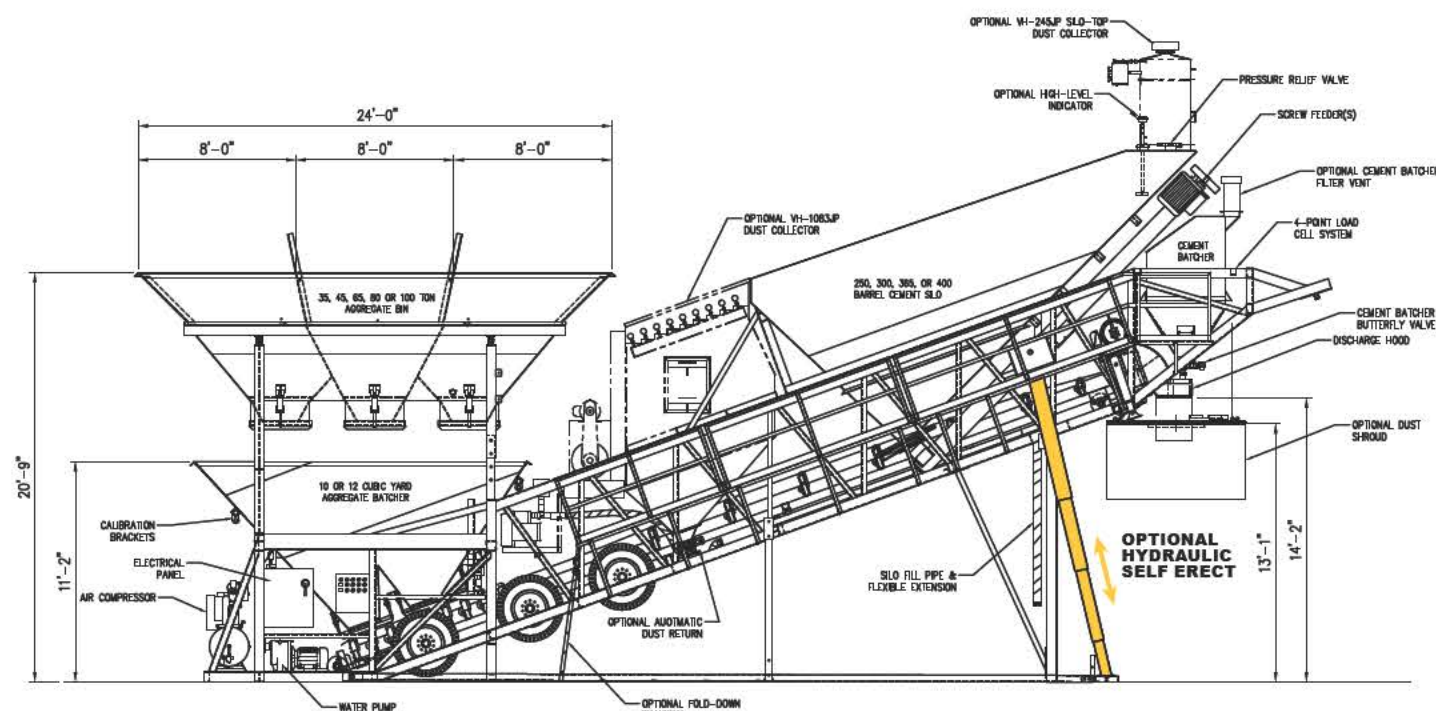

OPERATING POSITION

HYDRAULIC SELF ERECT OPTION

ELIMINATES THE NEED & COST OF CRANES - FAST & EASY SET UP IN REMOTE LOCATIONS





STANDARD HAGANATOR MODELS	HT-12250A-45	HT-12-12300B-65	HT-12-12400C-65	SUPER HT-12500D-80
CAPACITY (THEORETICAL)	90-120 YPH (TRANSIT MIX)	130-170 YPH (TRANSIT MIX)	160-220 YPH (TRANSIT MIX)	UP TO 400 YPH (CENTRAL MIX)
AXLES (DUAL TIRES, 10-HOLE WHEELS & AIR BRAKES)	TANDEM	TRIPLE	TRIPLE	FOUR
DISCHARGE HEIGHT (STEEL CLEARANCE)	14'-6"	14'-2"	14'-2"	14'-10"
OVERHEAD BIN, 3 OR 4 COMPARTMENTS (BOTH SIDES FOLD DOWN FOR TRAVEL)	45 TON/33.3 CY YES	65 TON/48.1 CY YES	65 TON/48.1 CY YES	80 TON/59.2 CY YES
AGGREGATE BATCHER SIZE	12 YARDS - 40,000#	12 YARDS - 40,000#	12 YARDS - 40,000#	12 YARDS - 40,000#
4 POINT LOAD CELL 20K EACH	YES	YES	YES	YES
AGGREGATE BATCHER GATES	2 DOUBLE CLAM	2 DOUBLE CLAM	2 DOUBLE CLAM	2 DOUBLE CLAM
TRANSFER BELT CONVEYOR	24"/15 HP 380 FPM	30"/20 HP 380 FPM	36"/30HP 380 FPM	48"/60 HP 650 FPM
DEEP TROUGHING IDLERS	35 DEGREES	35 DEGREES	35 DEGREES	35 DEGREES
CEMENT SILO (IN-TRUSS DESIGN)	250 BBL/1000 CU. FT.	300 BBL/1200 CU. FT.	400 BBL/1600 CU. FT.	500 BBL/2000 CU. FT.
CEMENT FEEDERS, MULTI-FLIGHT (REVERSIBLE & INDEPENDENTLY CONTROLLED)	TWIN 7"/10HP/42 CFM YES	TWIN 10"/15HP/100 CFM YES	TWIN 12"/25HP/240 CFM YES	TWIN 12"/25HP/240 CFM YES
CEMENT BATCHER SIZE	12 YARDS - 10,000#	12 YARDS - 10,000#	12 YARDS - 10,000#	12 YARDS - 10,000#
4 POINT LOAD CELL (3K EACH)	YES	YES	YES	YES
CEMENT BATCHER DISCHARGE	10" BUTTERFLY	10" BUTTERFLY	10" BUTTERFLY	10" BUTTERFLY
WATER METER (PIPING TO DISCHARGE)	2" TURBO	3" TURBO	3" TURBO	3" TURBO
AIR COMPRESSOR	10 HP	15HP	15 HP	20 HP
ELECTRICAL SERVICE (PRE-WIRED IN EMT CONDUIT)	460V/3PH/60HZ	460V/3PH/60HZ	460V/3PH/60HZ	460V/3PH/60HZ
TRAVEL DIMENSIONS:				
LENGTH (KING PIN TO REAR)	61'-0"	61'-0"	61'-0"	65'-6"
WIDTH	12'-0"	12'-0"	12'-0"	12'-0"
HEIGHT	14'-6"	14'-6"	14'-6"	14'-6"
WEIGHT	52,000#	56,000#	64,000#	87,000#

SHT SERIES

SUPER HAGANATOR TRAVEL-ALL

- 500 Barrel Storage
- Incorporate a Tilt or Horizontal Shaft Mixer for Wet Batch
- 6" Risers - Longer Truss



HCA SILO

MOBILE AUXILIARY SILO FOR CEMENTIOUS MATERIAL

The Vince Hagan HCA completely mobile auxiliary cement or fly ash storage silo is also available. It features an in-truss frame design for easy travel and set up. This low profile silo is the largest in the industry with up to 500 BBL of storage capacity.

- 300, 400, 500 brels of storage
- Travels as one unit
- Screw feeder travels in-frame
- 7", 10", 12" size screws
- Holds 2 tanker loads of material
- Allows for Silo-Top Dust Collector
- Can add an HCB Batcher or central dust collection

Max capacity based on cement at 94 lb/cu. ft.
Min capacity based on cement at 60 lb/cu. ft.

Cement fully aerated @ 70#/cu. ft. - Unaerated @ 94#/cu. ft.
Fly ash fully aerated @ 55#/cu. ft. - Unaerated @ 70#/cu. ft.



HCA MOBILE AUXILIARY SILO IN TRAVEL POSITION

HYDRAULIC SELF ERECT OPTION

ELIMINATES THE NEED & COST OF CRANES - FAST & EASY SET UP IN REMOTE LOCATIONS





EXCLUSIVE IN-TRUSS JET PULSE DUST COLLECTOR

The high efficiency system travels with the plant. Eliminates one load of freight. No silo top dust collector required. Auto dust recycle available



OVERHEAD AGGREGATE STORAGE SECTION

45 ton - 120 ton capacity. Up to four compartments. Sides fold down for easy travel. Two heavy-duty discharge gates per compartment. Largest aggregate bin available that travels with the plant.



AIR SUPPLY

Mounted air compressor with tank. Sized to meet plant requirements. Complete air piping mounted on the plant. Desiccant air dryer available.



ELETRICAL CONTROLS

Manual electric push-button control panel or automation ready NEMA enclosure. Electric air control valves with emergency manual override. Complete wiring in EMT conduit to NEC Standards. Main disconnect with motor starters mounted in NEMA panel. Special electrical requirements and plexiglass shield available.



WORK PLATFORMS & WALKWAYS

Safety without compromising portability. Include this option for easy accessibility and maintenance. Folds up and travels with the plant. All platforms and walkways can be painted safety yellow.



IN-TRUSS CEMENT SILO

250 - 500 BBL cement storage, largest in the industry (4 cu. ft. per BBL). In-truss frame design includes fill pipe, pressure relief valve, piped aeration system, manhole, and dual discharge with emergency slide gates. Optional split silo available.



SCREW FEEDERS

Twin 7", 10", or 12" screw feeders. Fastest available with 1/2 pitch initial flight to prevent packing, TEFC electric motor, inspection plates, clean out doors, and emergency reversing starters.



DUST SHROUD

Various shroud options available to match transit mixer, (three sided fixed, "baby buggy", or telescopic). All designed for high efficiency dust collection.



















APPENDIX B
Site Description

LAFARGE CANADA INC.

#300, 115 Quarry Park Road SE, Calgary, Alberta T2C 5G9
Phone: (403) 225-5400 Fax: (403) 278-2738
www.lafarge.ca

LEGEND

-  SPILL KIT
-  EMERGENCY RESPONSE MUSTERING AREA
-  FIRE EXTINGUISHER
-  LEVEL 2 FIRST-AID KIT
-  EYE WASH LOCATION
-  DIRECTION OF EXIT
-  DIRECTION OF DRAINAGE
-  AED
-  HWS HAZARDOUS WASTE STORAGE
-  DFS DIESEL FUEL STATION
-  SC SECONDARY COTAINMENT - ADMIXTURE, MOTOR OIL, FORM RELEASE
-  GAS SHUT OFF
-  W WATER SHUT OFF
-  MSDS
-  MH MAN HOLES
-  CB CATCH BASINS

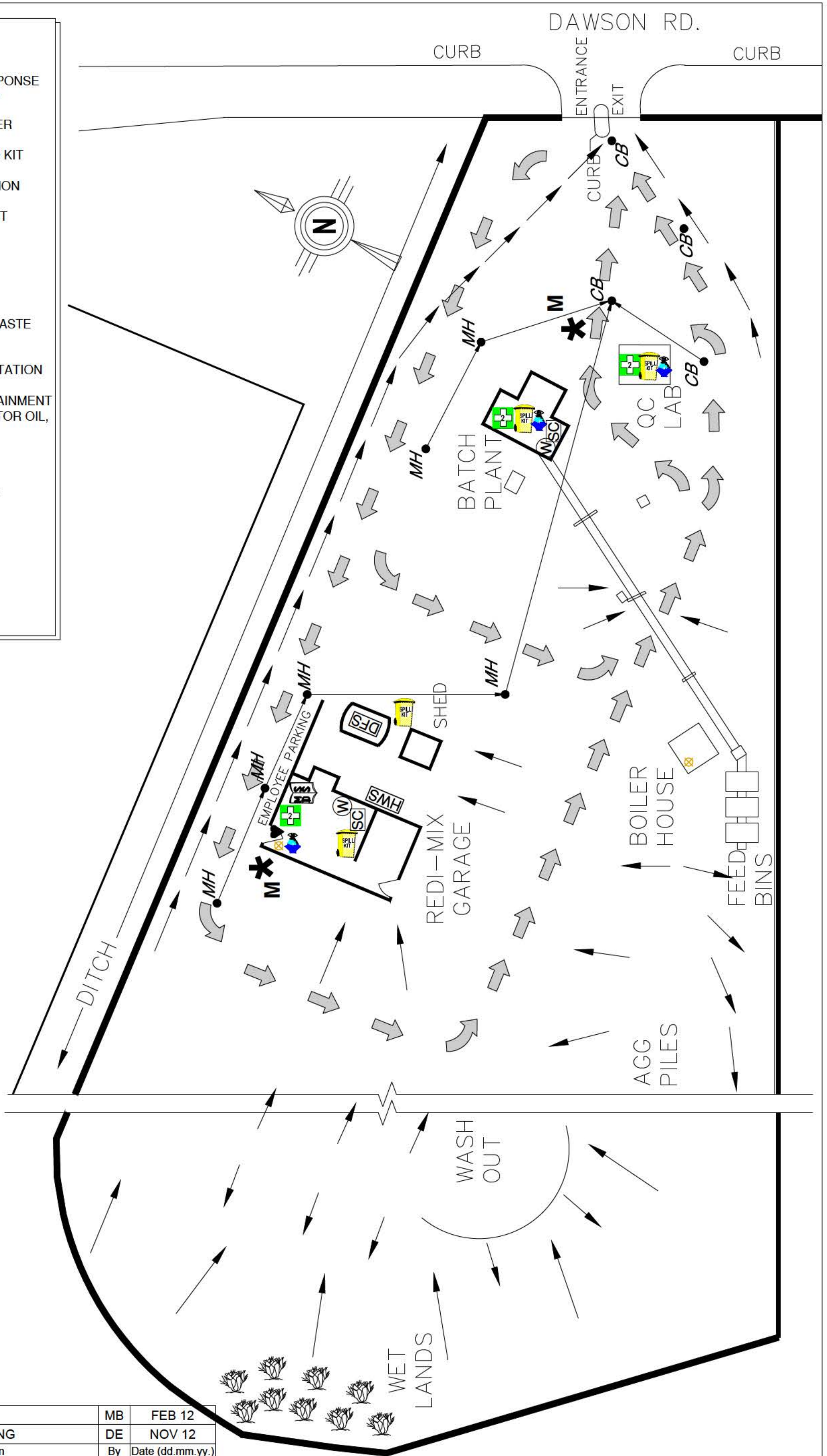

1	FINAL DRAWING	MB	FEB 12
0	PRELIMINARY DRAWING	DE	NOV 12
No.	Description	By	Date (dd.mm.yy.)

 <p>185 DAWSON ROAD, WINNIPEG, MB R2J 0S6 PH:(204) 958-6333</p>	Project REDI-MIX SITE DIAGRAM	Date	Scale	REV
	Sheet Title SITE DIAGRAM	02.29.2012	N.T.S.	1



APPENDIX C

Chemicals and Storage Volumes

LAFARGE CANADA INC.

#300, 115 Quarry Park Road SE, Calgary, Alberta T2C 5G9

Phone: (403) 225-5400 Fax: (403) 278-2738

www.lafarge.ca



Inventory Date: December 1, 2020

Containment Area Name: Admix Room

Conditions of Containment (Check for cracks, spillage, spent/unused chemicals, signage empty containers, labels, etc.):

Chemical/Material Name	Manufacturer	Maximum Quantity	Chemical Type	UN Number	TDG Class	Incompatible Materials	Storage Requirements	WHMIS/GHS Class	Special Considerations (Hazards)
MasterGlenium 3030	BASF	1 x 4000 L	Liquid Mixture - Polycarboxylate ether	-	-	Strong Acids Strong Bases Strong Oxidizing Agents Strong Reducing Agents	Tightly close container. Cool, dry, well ventilated area. Do not freeze	None Noted	-
Masterset FP 20	BASF Canada Inc.	1 x 4000 L	Admix - Calcium nitrate	-	-	strong acids, strong bases, strong oxidizing agents	Keep only in the original container in a cool, wellventilated place. Protect from direct sunlight. Store protected against freezing. Protect from temperatures below: 0 °C	Corrosive Exclamation Mark Health Hazard Danger	Harmful if swallowed. May cause an allergic skin reaction. May cause cancer. Causes severe skin burns and eye damage.
PS1466	BASF Canada Inc.	1 x 4000 L 1 x 300 gallons	Admix - ethanol	-	-	zinc, aluminium, oxidizing agents, strong alkalis, acids	Keep only in the original container in a cool, dry, wellventilated place away from ignition sources, heat or flame. Protect from direct sunlight. Store protected against freezing. Protect from temperatures below: 5 °C The packed product must be protected from temperatures below the indicated one. Protect from temperatures below: 40 °F	Corrosive Exclamation Mark Danger	May cause an allergic skin reaction. Causes severe skin burns and eye damage. Harmful to aquatic life. Harmful to aquatic life with long lasting effects.
MASTERSURE Z60	BASF	1 x 4000 L	Liquid Admixture	-	-	Strong Acids, Strong Bases, Strong Oxidizing Agents, Strong Reducing Agents	Keep only in original container. Cool, dry, well ventilated area. Keep away from ignition sources, flame or heat Protect from direct sunlight Do not store below 5 oC	None Noted	-
Master Air AE200 (Micro air)	BASF	1 x 4000 L	Admixture - Contains Acid	-	-	Strong Acids Strong Bases Strong Oxidizing Agents Strong Reducing Agents	Keep in original container Keep in a cool, dry, well ventilated area Keep awayfrom ignition sources, heat or flame Protect from sunlight Do not freeze	Exclamation Point Warning	Causes serious eye irritation May cause an allergic skin reaction.
Rheobuild 1000 (R1000)	BASF	1 x 4000 L	Liquid Mixture - Naphthalene sulfonates	-	-	strong acids, strong bases, strong oxidizing agents, strong reducing agents	Keep only in the original container in a cool, dry, wellventilated place away from ignition sources, heat or flame. Protect from direct sunlight. Protect from temperatures below: 5 °C	None Noted	None Noted
MasterSet Delvo	BASF	1 x 4000 L	Liquid Mixture - Phosphoric Acid (up to 15%)	-	-	Strong Acids Strong Bases Strong Oxidizing Agents Strong Reducing Agents	Keep only in original container. Cool, dry, well ventilated area. Keep away from heat, ignition sources or flame Protect from direct sunlight Do not freeze	Exclamation Mark Warning	Causes serious eye irritation. Causes skin irritation. May cause an allergic skin reaction.
Master X-Seed 55	BASF Canada Inc.	1 x 4000 L	Liquid Mixture	-	-	strong acids, strong bases, strong oxidizing agents, strong reducing agents	Keep only in the original container in a cool, dry, wellventilated place away from ignition sources, heat or flame. Protect from direct sunlight.	Corrosive Danger	Causes serious eye damage.
MasterPolyheed 980	BASF Canada Inc.	1 x 4000 L	Admix	-	-	strong acids, strong bases, strong oxidizing agents, strong reducing agents	Keep only in the original container in a cool, dry, wellventilated place away from ignition sources, heat or flame. Protect from direct sunlight. Protect from temperatures below: 5 °C	Exclamation Mark Warning	Causes serious eye irritation

MasterPolyheed 997	BASF Canada Inc.	1 x 900 gallons 1 x 300 gallons	Liquid Mixture - sodium nitrate	-	-	strong acids, strong bases, strong oxidizing agents, strong reducing agents	Keep only in the original container in a cool, dry, wellventilated place away from ignition sources, heat or flame. Protect from direct sunlight. Protect from temperatures below: 0 °C	Corrosive Danger	Causes serious eye damage
MASTER POZZOLITH 210	BASF	1 x 900 gallons	Liquid Admixture - Nitritotriethanol	-	-	strong acids, strong bases, strong oxidizing agents, strong reducing agents	Keep only in original container. Cool, dry, well ventilated area. Keep away from ignition sources, flame or heat Protect from direct sunlight Do not store below 5 oC	None Noted	-
MASTERSSET AC 534	BASF	1 x 900 gallons	Liquid Admixture - Calcium Nitrate	-	-	strong acids, strong bases, strong oxidizing agents, strong reducing agents	Keep only in the original container in a cool, dry, wellventilated place away from ignition sources, heat or flame. Protect from direct sunlight. Protect from temperatures below: -25 °C	Corrosive Danger	Harmful if swallowed. Causes serious eye damage

Notes:

Photos:

Chemicals on Site	
Name of Chemical	Max. Storage Volume (L)
210 N	5000
Diesel	5000
980 - BASF	5000
Micro Air	5000
Generator Oil	20



APPENDIX D

MRMCA Concrete Certification Standard

LAFARGE CANADA INC.

#300, 115 Quarry Park Road SE, Calgary, Alberta T2C 5G9
Phone: (403) 225-5400 Fax: (403) 278-2738
www.lafarge.ca

Best Management Practice

READY MIX CONCRETE PLANTS

© 2000, Manitoba Heavy Construction Association Inc. All rights reserved. No part of this publication may be reproduced, stored in any material form (including photocopying or storing it in any medium by electronic means and whether or not transiently or incidentally to some other use of this publication) without the written permission of the copyright holder except in accordance with the provisions of the Copyright Act. Warning: The doing of an unauthorized act in relation to a copyrighted work may result in both a civil claim for damages and criminal prosecution.

Note:

This Best Management Practice (BMP) and all supporting materials are only a guideline and supplement to the interpretation of existing legislation and industry practices. It is designed and intended to help and assist members of the heavy construction industry in developing and implementing their own environmental management system. This BMP is not legislation, is not intended to replace any legislation and does not guarantee establishing a successful "due diligence" defense in the event of legal action. This BMP and all supporting materials are not to be reproduced without written permission from the Manitoba Heavy Construction Association. No warranty is made with regard to this BMP and its contents, and all supporting materials and their contents.

The material in this BMP may be incorporated into the working knowledge of the reader but its use should be subjected to the particular circumstances of each user.

ACKNOWLEDGEMENTS

This document has been a joint effort between members of the Manitoba Heavy Construction Association (MHCA) and the Manitoba Ready Mix Concrete Association. Having all stakeholders involved in its development has been beneficial. The MHCA would like to acknowledge all who were involved in the development of the document. The document will be distributed to and used for training of, the ready mix industry throughout Manitoba.

1. INTRODUCTION

1.1. Purpose

The Best Management Practices (BMP) was developed to assist owner(s) and operators of Ready Mix Concrete Facilities to adopt best practices in order to improve the environment, protect human health and safety, and reduce potential risks and economic liabilities at their work site.

This document outlines recommended operational practices that will minimize the impact of Ready Mix concrete plants on the environment and promote safety at the workplace. The document can be used for new facilities or for upgrading existing facilities.

BMP is intended to identify best management practices as a supplement to the requirements of existing legislation. BMP is NOT intended to create or replace any legislation, industry standards, code or guidelines. BMP does not guarantee a successful "due diligence" defense in the event of legal action. Although reference is made in BMP to provincial statutes and regulations, where federal legislation is applicable (such as on First Nation Lands, or National Park Lands) such legislation shall also be complied with. As well, municipal by-laws and other industry standards and codes should be observed.

This document was developed in April 2000. The document will be reviewed every three years to ensure the information is up to date, relevant to the industry and reflects changes in industry practices and legislation.

1.2. Background

In the overall context of industrial facilities, ready mix concrete plants do not generally pose a significant problem in terms of environmental impact. The usual ingredients that are combined to produce concrete as outlined by the Cement Association of Canada, as follows:

> Course aggregate	48% by weight	31-51% by volume
> Fine aggregate	31%	24-48%
> Portland cement	13%	7-15%
> Water	8%	14-18%
> Admixture chemicals (control characteristics such as air entrainment, water/cement ratio, initial set time, and compressive strength)		200-5000 milligrams
> Air	N/A	4-8%

These ingredients are typically deposited at the plant into a transit-mix concrete truck for mixing and transport. Occasionally, the plant itself is designed to mix all ingredients before depositing the batch into the delivery truck. No heat is involved in the production except heating of water and/or the making of steam for aggregate heating in winter production.

Emissions, as a result of this mixing operation are limited, but may include vehicular emissions, noise and dust particles from aggregate piles or from the mixing process becoming airborne in the drum or on being released from the silo. Surface drainage and wastewater and solid waste management may pose site management issues at ready mix concrete facilities.

2. GENERAL - Compliance with the Law

- Take all reasonable steps to identify all applicable laws, including legislation, regulations, municipal by-laws and codes. Comply with all aspects of applicable laws.
- Obtain all proper and applicable licenses, permits and Certificate of Approvals for site operations.

3. PERMANENT PLANTS (see Appendix A for Definition)

- The owner/operator shall make efforts to minimize noise nuisance created as a result of the operation.
- Spent bag house filters should be disposed of in an environmentally friendly manner.
- To every extent possible, the owner/operator should practice the best environmental practices listed under Sections 5.1, 6.0, and 7.0 at the permanent plant.
- All environmentally related activities should be recorded.

4. PORTABLE PLANTS (see Appendix A for Definition)

- All portable plants must be pre-registered with Manitoba Conservation; the Department must be advised of their site location each time they are relocated.
- Siting of portable plants should be to every extent possible reviewed and sited at an early stage in connection with the local Municipal Authority and Manitoba Conservation Environment Officer.
- The owner/operator should consult with adjacent landowners.
- All environmentally related incidents should be recorded.
- To every extent possible, the owner/operator should practice the best environmental practices listed under Sections 5.1, 6.0, and 7.0 at the portable plant.
- After removal of the portable plant from a property, leave the site in a neat and clean condition; sites should be left in an aesthetically acceptable condition.

5. SITE MANAGEMENT

5.1. General Site Management

- Plastic concrete is toxic to fish (e.g. high pH and reducing the BOD) and therefore must not enter watercourses. Efforts to ensure catchment of wet concrete must be implemented on-site (e.g. a drop sheet).
- Where practical and appropriate, mitigation measures should be implemented to protect fine aggregate stockpiles from wind erosion.
- In an urban or highly populated setting, dust suppressants such as calcium chloride should be used on internal plant roads to minimize dust carrying off the site. Water is an example of an environmentally friendly dust suppressant.
- Runoff from the concrete plant site should be minimized to prevent contamination.
- Use good housekeeping practices to clean up spills of cement and concrete as soon as possible.
- It is recommended that incidents occurring at the concrete plant be recorded.
- Staff involved in concrete production should be made aware of this BEMP.

5.2. Site Water Management

A reduction in water usage could be achieved by the following options:

- Monitoring/auditing of water usage;
- Use water reducing admixtures which reduce the amount of given water in the batch concrete;
- Capture and reuse wash water;
- Restrict freshwater uses to truck exterior wash off, hot water production and batch water for high quality concrete;
- Install flow controls on freshwater sources, where practical;
- Recycle water, where practical; and
- Train employees to minimize water use and on water conservation practices.

- Conduct chemical washing of trucks in a safe manner (appropriate PPE).
- The resultant wash, which is generally neutralized, should be disposed of using a safe and environmental practice.
- Use a sloped settling pond for washout, where practical.
- Where necessary and practical, containment of wastewater and surface runoff is recommended.

5.3. Site Air Management

To improve air quality at Ready Mix facilities, one can follow such examples:

- Install effective dust removal devices such as bag houses on vents from pneumatic or mechanical transfer systems;
- Use curtains or socks for truck loading operations;
- Minimize surface areas of aggregate storage piles;
- Locate aggregate storage piles in area sheltered from wind, where practical;
- Pave high vehicle traffic areas and use dust control, where practical;
- Reduce speed limits;
- Routine sweeping of paved portions of yard to remove accumulated dust; and
- For aesthetic and environmental purposes, one should consider planting vegetation (i.e. trees) around the site.

6. MATERIALS MANAGEMENT

6.1. Pollution Prevention: General

- The owner/operator should implement a high standard of equipment and maintenance, and good housekeeping and operational practices, at all times.

6.2. Chemical and Fuel Management

- Proper storage of lead batteries, solvents and waste oil for recycling.
- Ensure containment at fuel and chemical handling areas is sufficient.
- Install proper WHMIS signage to identify contents of bulk tanks.
- Facility operators should be familiar with appropriate sections of the Manitoba Environment Act and any other applicable guidelines, codes and local land use permits with regards to handling and storage of fuels.
- The Owner/Operator shall obtain all necessary permits from Manitoba Conservation for the handling and storage of fuel products and shall keep copies available for reference.
- Take adequate precautions to ensure that diesel fuel, oil, grease and other transportable material do not enter surface and groundwater courses. For example:
 - > Fuels, lubricants and other potentially hazardous materials as defined in the Manitoba Dangerous Goods Handling and Transportation Act shall be stored and handled within the designated storage area(s).
 - > The Owner/Operator should ensure that all equipment is maintained such that it poses a minimum risk to the environment.
 - > The Owner/Operator should ensure that all fuel storage containers are inspected, for leaks and spillage of hazardous fluids, (such as oil) on a regular basis, and repairs carried out immediately.
 - > When servicing requires the drainage or pumping of fuels, lubricating oils or other fluids from equipment, suitable spill response equipment (such as spill trays and spill kits) should be available to catch the fluid, contain, and collect small spills.

7. WASTE MANAGEMENT

7.1. Non-Hazardous Waste

- The Owner/Operator when necessary should undertake site clean-ups with all resulting debris deposited at a Waste Disposal Ground operating under the authority of Manitoba Regulation 150/91. Exceptions are liquid industrial and hazardous wastes, which require special disposal methods.
- Indiscriminate dumping or littering shall not take place.
- No burning or burying of wastes at the concrete plant sites (both permanent and portable) shall be allowed unless approved by appropriate authorities.
- Reuse returned concrete for other purposes, where practical.
- Incorporate returned concrete in succeeding batches where operational and quality constraints allow.
- Wherever possible sludge should be recycled for other purposes, where practical.
- When disposing of all other solid waste, i.e. paper, wood, metals refuse, etc. that it may be carried out with consideration for reuse & recycle.

7.2. Hazardous Waste

- Dangerous goods/hazardous waste is identified by, and shall be handled according to the Manitoba Dangerous Goods Handling and Transportation Act and associated Regulations.
- The Owner/Operator shall have on site staff that is trained and/or knowledgeable in the handling and transportation of dangerous/hazardous goods, when said dangerous goods/hazardous wastes are being utilized.
- Used oils shall not be used for dust suppression unless approved by appropriate authorities
- Used oils shall be stored in appropriate drums, or tanks with signage until shipped to used oil recycling centres, incinerators or disposal facilities approved for such wastes.
- Used oil filters shall be drained, placed in suitable storage containers, and disposed of in an appropriate manner.

8. EMERGENCY RESPONSE

- The Owner/Operator should ensure that there is an Emergency Management Plan in place, and that it has been communicated to all employees.
- The Owner/Operator should designate an on-site Emergency Response Coordinator (ERC) for the project. The ERC shall have the necessary training, authority, and responsibility to redirect manpower in order to respond to an emergency. The Emergency Response Coordinator (ERC) shall be familiar with the Emergency Management Plan, and have on site a list of telephone numbers to call in the event of an emergency, and a map to the closest hospital including at least Manitoba Conservation, Environment Canada, emergency company contacts, and the local fire and police departments.
- The Owner/Operator shall report and document all environmental accidents involving contaminants (as defined in Appendix B) to Manitoba Conservation, immediately after occurrence of the environmental incident, by calling the 24-hour emergency phone number, in accordance with Manitoba Regulation 439/87.
- In general, the following actions shall be taken by the first person(s) arriving at the scene (first responder) of a spilled dangerous good/hazardous waste:
 1. Secure area and ensure safety;
 2. Assess the situation/risks and identify spilled material;
 3. Respond (e.g. get help, eliminate source of ignition, contain, block sewers etc.), if it is safe to do so.
 4. Notify, verbally, the appropriate government agency immediately. Follow up with a written document (fax).
 5. Manage spilled material, if it is safe to do so.
- When dangerous goods are used on site, materials for containment and cleanup of spill material (e.g. spill kit) should be available on site.
- Minor spills of such substances, less than reportable quantities shown in Appendix B, which may be contained on land with no significant impact on human health or the environment, may be responded to with in-house resources without formal notification of Manitoba Conservation.

9. ORIENTATION

- Each new worker should be given a plant orientation before they start work, which should include a tour of the plant and how it operates, where to find a telephone, emergency first-aid kit, fire extinguisher, who to report to and where to evacuate to, where the MSDS's are kept and the hazards at the plant.
- Always communicate with the plant operator, especially when you are doing any maintenance at the plant.
- Good housekeeping in the yard and plant will go a long way to preventing trips and falls.
- Each worker should know about the chemicals on site and the proper PPE to wear and where the PPE is kept.
- At a concrete plant, dust masks need to be with you at all times.
- Falling objects are a hazard at concrete plants therefore; Hardhats and steel-toed boots are required.
- Watch for traffic in a concrete yard and give right of way to all vehicles and be sure to make eye contact with the drivers before crossing their path.
- Wear the right PPE and read the MSDS when acid washing a truck and always work with your back to the wind.
- Never pour water into acid; dispense the acid into the water.
- Always use proper lifting procedure; Bend your knees, get under the load and lift with your legs.
- When cleaning a mixer drum in a ready mix truck, use full confined-space entry procedures and plan your work. And wear all necessary PPE at a minimum; eye protection, steel toed boots, gloves and hearing protection.
- Always have an entry watch person when cleaning the inside of a mixer drum. Both persons must have confined-space entry training.
- All pinch points within reach should be guarded and wear all PPE and clothing nice and snug
- Always use the 3-point contact method to mount and dismount a truck cab.
- Concrete is caustic avoid direct contact by using the appropriate PPE.

APPENDIX A: GLOSSARY OF TERMS

The following Glossary of Terms applies to the Ready Mix Concrete Facilities BEMP:

Aggregate: granular materials, such as sand, gravel, crushed stone, crushed hydraulic-cement concrete, or iron-blast finance slag, used with a hydraulic cementing medium to produce concrete or mortar.

Batch: quantity of either concrete or mortar mixed at one time.

Biochemical Oxygen Demand: the amount of oxygen required by bacteria while stabilizing decomposable organic matter under aerobic conditions.

Calcium Chloride: a crystalline solid, CaCl_2 : in various technical grades, used as a drying agent, as an accelerator of concrete, a de-icing chemical, and for other purposes.

Cement. Bulk: cement that is transported and delivered in bulk (usually in specially constructed vehicles) instead of in bags.

Concrete: a composite material that consists essentially of a binding medium within which are embedded particles or fragments of aggregate, usually a combination of fine aggregate or coarse aggregate; in Portland cement concrete, the binder is a mixture of Portland cement and water with or without supplementary cementing materials such as flyash, silica fume or slag.

Decibel: a comparative unit that measures the intensity of sound. It is the term to identify 10 times the common logarithm or the ratio of two like quantities proportional to power or energy.

De-Scaling Agent: chemicals used in water to prevent scale from forming on pipes and tanks/vessels. Bromine is a common de-scaling agent.

De-Watering: refers to a process used in detention/retention facilities, whereby water is completely discharged or drawn down to a pre-established pool elevation by way of a perforated pipe. De-watering allows the facility to recover its design storage capacity in a relatively short time after a storm event.

Dust Suppressant: an example is water. Other materials such as a calcium chloride solution can be applied without prior approval from a given jurisdiction.

Effluent: flowing forth or out.

Emission Source: from concrete plants includes: 1) diluted sources which are ducted to the atmosphere through a stack. 2) Fugitive emission emitted directly to the atmosphere from open sources i.e. from yard dust, loader and mixer travel, handling aggregate, wind erosion, etc.

Mechanical Reclaimer: any equipment that mechanically separate components of plastic concrete allowing the reuse of the individual components where operational and quality constraints allow.

Mixing. Water: the water is freshly mixed sand-cement grout, mortar, or concrete, exclusive of any previously absorbed by the aggregate.

Noise: unwanted or undesirable sound; sounds which create detrimental effects.

Opacity: means the degree to which an emission reduces the passage of light (obscures the view of an object in the background) expressed numerically from 0% (transparent) to 100% (opaque).

Permanent Plant: a permanent batch plant is one that remains in one location for more than 1 year.

pH: A rating scale from 0 to 14 of the degree of acidity or alkalinity in a solution. On the pH scale, pure water rates a 7.0 and concrete wash water is very alkaline, rating a score of 13. Any solution with a pH above 9.0 has adverse effects on fish.

Portable Plant: capable of being moved from one job site to another and sited for less than 365 days in a single location. A portable plant is where the aggregate batching and weighing system is contained on a unitized chassis wholly capable of being towed down a road to a remote job site. This chassis may or may not include the cement-weighing portion of the process. Sometimes, depending on the silo size, the cement silo is a separate entity. Portable plant can also include a mobile mixer.

Sludge: any thick, semi-fluid mass, usually a sediment or filtered waste product, muddy or slushy sediment.

Slurry: thin mixture of water and any several fine, insoluble materials.

Stormwater Treatment: detention, retention, filtering or infiltration of a given volume of stormwater to remove urban pollutants and reduce frequent flooding.

Truck Mixer: a vehicle specifically designed to mix and agitate concrete suitable for mounting on a truck chassis and capable of mixing concrete in transit.

APPENDIX B: REPORTABLE QUANTITIES

CLASSIFICATION	HAZARD	REPORTABLE QUANTITY OR LEVEL
1	Explosives	All
2.1	Compressed Gas (Flammable)	100L*
2.2	Compressed Gas	100L*
2.3	Compressed Gas (Toxic)	All
2.4	Compressed Gas (Corrosive)	All
3	Flammable Liquids	100 L
4	Flammable Solids	1 Kg
5.1 Packing Groups I & II	Oxidizer	1 Kg or 1 L
Packing Group III	Oxidizer	50 Kg or 50 L
5.2	Organic Peroxide	1 Kg or 1 L
6.1 Packing Group I	Acute Toxic	1 Kg or 1 L
Packing Groups II & III	Acute Toxic	5 Kg or 5 L
6.2	Infectious	All
7	Radioactive	Any discharge or radiation level exceeding 1.0 mSv/h at the package surface and 200 uSv/h at 1 m from the package surface
8	Corrosive	5 Kg or 5 L
9.1	Miscellaneous (except PCB mixtures)	50 Kg
9.1	PCB Mixtures	500 grams
9.2	Aquatic Toxic	1 Kg or 1 L
9.3	Wastes (Chronic Toxic)	5 Kg or 5 L

* Note: To be amended to other materials in the near future.

Source: Manitoba Dangerous Goods Handling and Transportation Act, Regulation 439/87: Environmental Accident Reporting Regulation.

BEST ENVIRONMENTAL MANAGEMENT PRACTICE